

N-SERIES

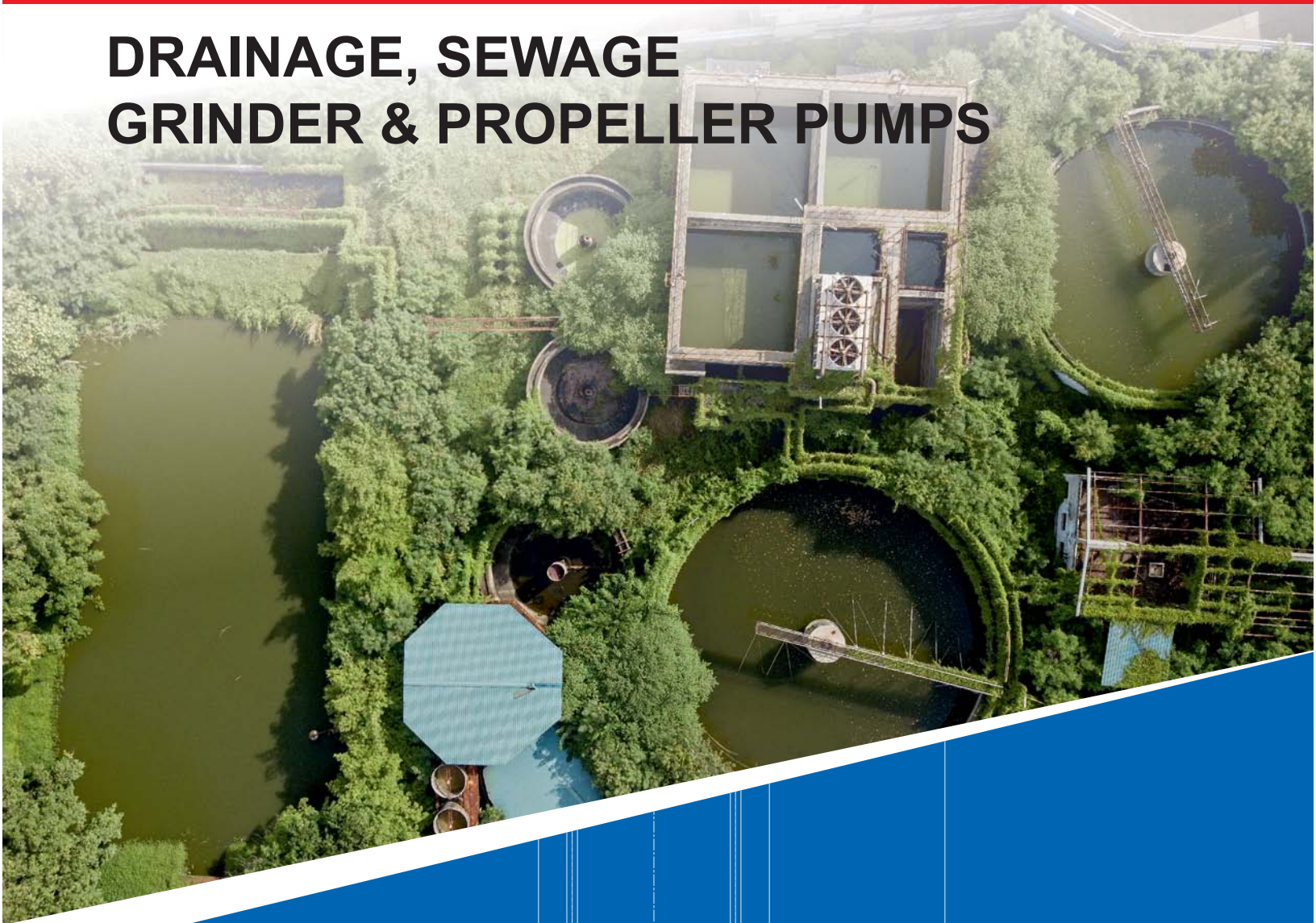

DRAINAGE, SEWAGE GRINDER & PROPELLER PUMPS



PRODUCT CATALOGUE

50Hz

www.northam-inc.com

DRAINAGE, SEWAGE GRINDER & PROPELLER PUMPS

CONTENTS

ND-S - Cast Iron Submersible Drainage Pump	03
ND-P - Corrosion Proof Submersible Drainage Pump	04
ND-A- Drainage Pumps (0.5 HP to 3.0 HP)	05
ND-F- Sewage Pumps (1.0 HP to 3.0 HP)	08
ND-B- Stainless Steel Submersible Effluent Vortex Pumps	11
ND-H- Heavy-Duty Sewage Pumps (5.0 HP to 60.0 HP)	14
ND-G- Grinder Pumps (2.0 HP to 5.0 HP)	21
ND-L- Large Volume Water Pumps (3.0 HP to 15.0 HP)	24
ND-M-Heavy-Duty Construction Drainage Pumps (1.5 HP to 15.0 HP)	27

CAST IRON SUBMERSIBLE DRAINAGE PUMP

GENERAL DATA

Performance Range

- ▶ Flow rate up to 11300 l/h (11.3 m³/h)
- ▶ Dynamic head up to 11 m.

Applications

- ▶ For clean water containing solids up to 10 mm grain size.
- ▶ As a sump pump for household applications.
- ▶ For draining flooded rooms or tanks.
- ▶ Extractions of water from ponds, flowing water or pits for collection of rain water.

Features

- ▶ Rugged cast iron pump housing, impeller, and motor casing.
- ▶ 230V thermally protected energy efficient motor.
- ▶ Oil filled motor for better heat dissipation.
- ▶ Permanently lubricated ball bearings.
- ▶ Extra long 4.6 mtrs. (15 feet) grounded power cord.
- ▶ 1½" BSP Discharge pipe size.
- ▶ Stainless steel shaft
- ▶ Stainless steel fasteners.
- ▶ Provide with 1½" flexible hose connection and clamp.
- ▶ Available with Sic/Sic mechanical shaft seal for pumping sandy water (optional).

Operating Conditions

- ▶ Ambient temperature : Max. +50°C
- ▶ Liquid temperature : 0°C to +50°C
- ▶ Max. Starts per hour : 30 at regular intervals.
- ▶ Duty Rating :
 - S1 - When pump is completely submerged.
 - S3 - When pump is partially submerged.

Model Designation

Automatic submersible drainage pump with	Models available	
	0.18 kW	0.37 kW
* Wide Angle Float Switch	ND-S521T	ND-S551T

Motor Specifications

- ▶ 230 V, 50 Hz, 1 Phase, 2850 RPM
- Oil Filled ; Thermally Protected

Direction of Rotation

- ▶ Clockwise as seen from the motor rear end.

Performance Table

Model	kW	HP	Amp	m ³ /h l/h	Flow Rate (m ³ /h)							Max. Lift (no flow) (mtrs)	Max. Solid Passage Size (mm)	Dimensions & Weight Data				Cable data Cable x core x size (mm ²) x length (m) x Material
					1	2	4	6	8	10	11			Major Width (mm)	Height (mm)	Gross Weight (kg.)	Volume (m ³)	
ND-S521T	0.18	0.25	2.0	H (m)	6.2	6.1	5.5	4.7	3.7	2.5	1.7	6.4	10	229	241	13.5	0.023	1 x 3 x 1.0 x 5 x PVC
ND-S551T	0.37	0.50	3.0		10.8	10.7	10.1	9.4	8.2	6.8	-	11	10	254	254	18.0	0.028	1 x 3 x 1.0 x 5 x PVC

Note : The above shown performance is nominal performance and may vary from pump to pump.



**Submersible drainage pump
with Wide angle float switch**

Performance Curve

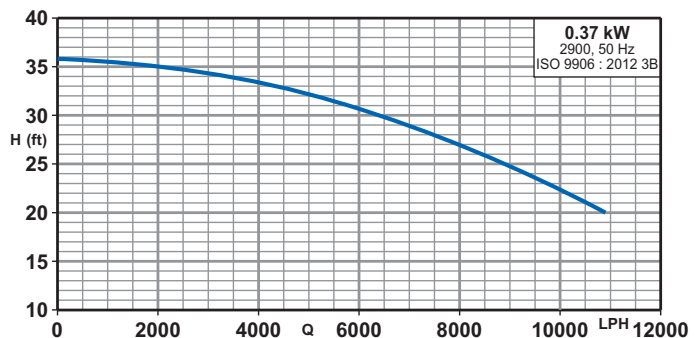
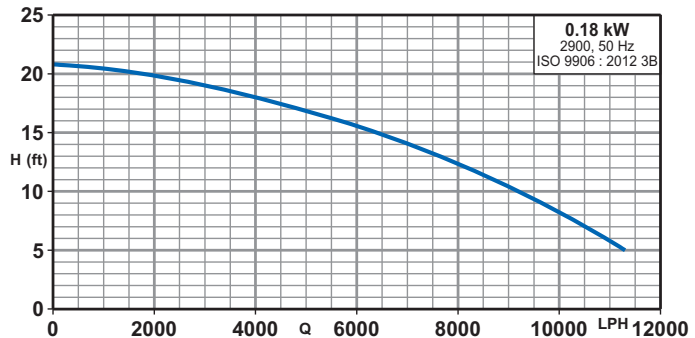

Minimum sump pit diameter

Model		Minimum Sump Pit Dia. (mm)
ND-S521T	*	381
*	ND-S551T	406

CORROSION PROOF SUBMERSIBLE DRAINAGE PUMP

GENERAL DATA

Performance Range

- ▶ Flow rate up to 20900 l/h (20.9 m³/h)
- ▶ Dynamic head up to 13 m.

Applications

- ▶ For clean water containing solids up to 10 mm grain size.
- ▶ As a sump pump for household applications.
- ▶ For draining flooded rooms or tanks.
- ▶ Extractions of water from ponds, flowing water or pits for collection of rain water.

Features

- ▶ Corrosion resistant composite construction.
- ▶ 230V thermally protected energy efficient motor.
- ▶ Oil filled motor for better heat dissipation.
- ▶ Permanently lubricated ball bearings.
- ▶ Extra long 4.6 mtrs. (15 feet) grounded power cord.
- ▶ 1½" Discharge pipe size.
- ▶ Stainless steel shaft
- ▶ Stainless steel fasteners.
- ▶ Provide with 1½" flexible hose connection and clamp.
- ▶ Available with Sic/Sic mechanical shaft seal for pumping sandy water (optional).

Operating Conditions

- ▶ Ambient temperature : Max. +45°C
- ▶ Liquid temperature : +5°C to +45°C
- ▶ Max. Starts per hour : 30 at regular intervals.
- ▶ Duty Rating :
 - S1 - When pump is completely submerged.
 - S3 - When pump is partially submerged.

Model Designation

Automatic submersible drainage pump with	Models available	
	0.18 kW	0.37 kW
* Wide Angle Float Switch	ND-P521T	ND-P551T

Motor Specifications

- ▶ 230 V, 50 Hz, 1 Phase, 2850 RPM (syn.)
- ▶ Oil Filled ; Thermally Protected

Direction of Rotation

- ▶ Clockwise as seen from the motor rear end.

Performance Table

Model	kW	HP	Amp	m ³ /h l/h	Flow Rate (m ³ /h)										Max. Lift (no flow) (mtrs)	Max. Solid Passage Size (mm)	Dimensions & Weight Data				Cable data cable x core x size (mm ²) x length (m) x Material
					2	4	6	8	10	12	14	16	18	20			Major Width (mm)	Height (mm)	Gross Weight (kg.)	Volume (m ³)	
ND-P521T	0.18	0.25	2.0	H (m)	6.5	5.9	5.2	3.9	2.2	-	-	-	-	-	6.8	10	241	241	8.0	0.022	1 x 3 x 1.0 x 5 x PVC
ND-P551T	0.37	0.50	3.0		12.9	12.5	12	11.2	10.2	8.9	7.7	6.1	4.5	2.5	13	10	267	267	9.0	0.028	1 x 3 x 1.0 x 5 x PVC

Note : The above shown performance is nominal performance and may vary from pump to pump.



**Submersible drainage pump
with Wide angle float switch**

Performance Curve

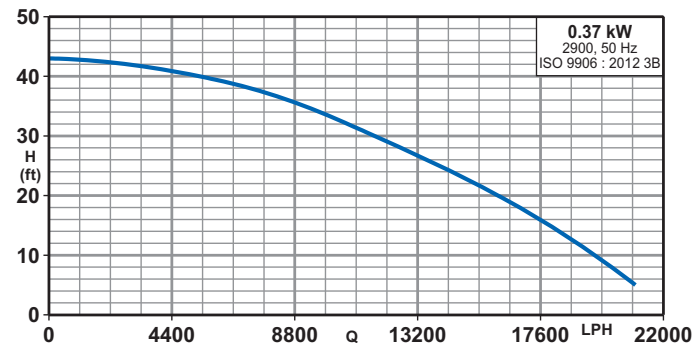
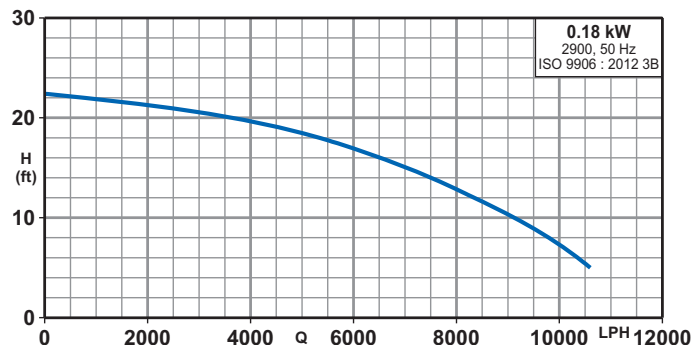

Minimum sump pit diameter

Model	Minimum Sump Pit Dia. (mm)
ND-P521T	*
*	ND-P551T
	381
	432

DRAINAGE PUMPS

GENERAL DATA 0.5 HP to 3.0 HP

Performance Range

- ▶ Flow rate up to 1000 l/min. (60 m³/h)
- ▶ Dynamic head up to 29 m.

Applications

- ▶ Slushy water, waste water without solids, sump drainage.
- ▶ Drainage application, flood control.
- ▶ Dewatering for fish pond or basement.

Features

- ▶ New design for light weight, elegant shape with best quality.
- ▶ Unfastening the bolts between the oil casing and the upper pump casing allows the body to be separated for easy maintenance.
- ▶ All pumps are furnished with double mechanical seal. All pumps up to 0.75 kW have carbon/ceramic sealing faces at both water end and motor end. All pumps starting with 1.5 kW and above have Sic sealing faces at the water end and carbon/ceramic sealing faces at the motor end.
- ▶ Available with Sic/Sic mechanical Shaft seal for pumping sandy water for 0.75 kW (optional).

Special Features on Request

- ▶ Other voltages.
- ▶ Available in 60Hz.

Direction of Rotation

- ▶ Clockwise as seen from the motor rear end.

Thermal overload protector

- ▶ Equipped with Automatic reset motor protector, prevents motor from burning due to high temperature/phase failure/voltage drop and lock impeller.



Cable base

- ▶ Epoxy resin seal cable base to prevent water intrusion into motor through the cable wire.

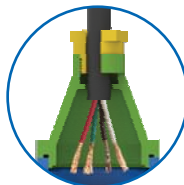

Motor

- ▶ 2 - pole dry submersible motor
- ▶ 50Hz (n = 2900 RPM)
- ▶ Single phase : 230V +5 - 15 %
- ▶ Three phase : 400V +5 -15 %
- ▶ Protection IP 68
- ▶ Insulation class : F

Operating Conditions

- ▶ Ambient temperature : Max. +50°C
- ▶ Liquid temperature : 0°C to +50°C
- ▶ Max. Starts per hour : 30 at regular intervals.
- ▶ Duty Rating :
 - S1 - When pump is completely submerged.
 - S3 - When pump is partially submerged.

Float Switch Pump

- ▶ The pumps are equipped with wide angle on/off level control float switch for easy and simple automatic operation.
- ▶ Applications : Slushy water, dewatering, drainage application.
- ▶ Type : 0.37 - 2.2 kW Single-phase pumps.
0.37 - 2.2 kW Three-phase pumps.

U Type Impeller

- ▶ This impeller can generate rapid rotating vortex to handle fluid mixed with long fiber, the majority of abrasive solids do not touch impeller to minimize impeller wear.

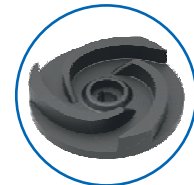

Float Switch

- ▶ Excellent quality float switch Provided with epoxy resin sealed connector.



DRAINAGE PUMPS

MATERIAL OF CONSTRUCTION

0.5 HP to 3.0 HP

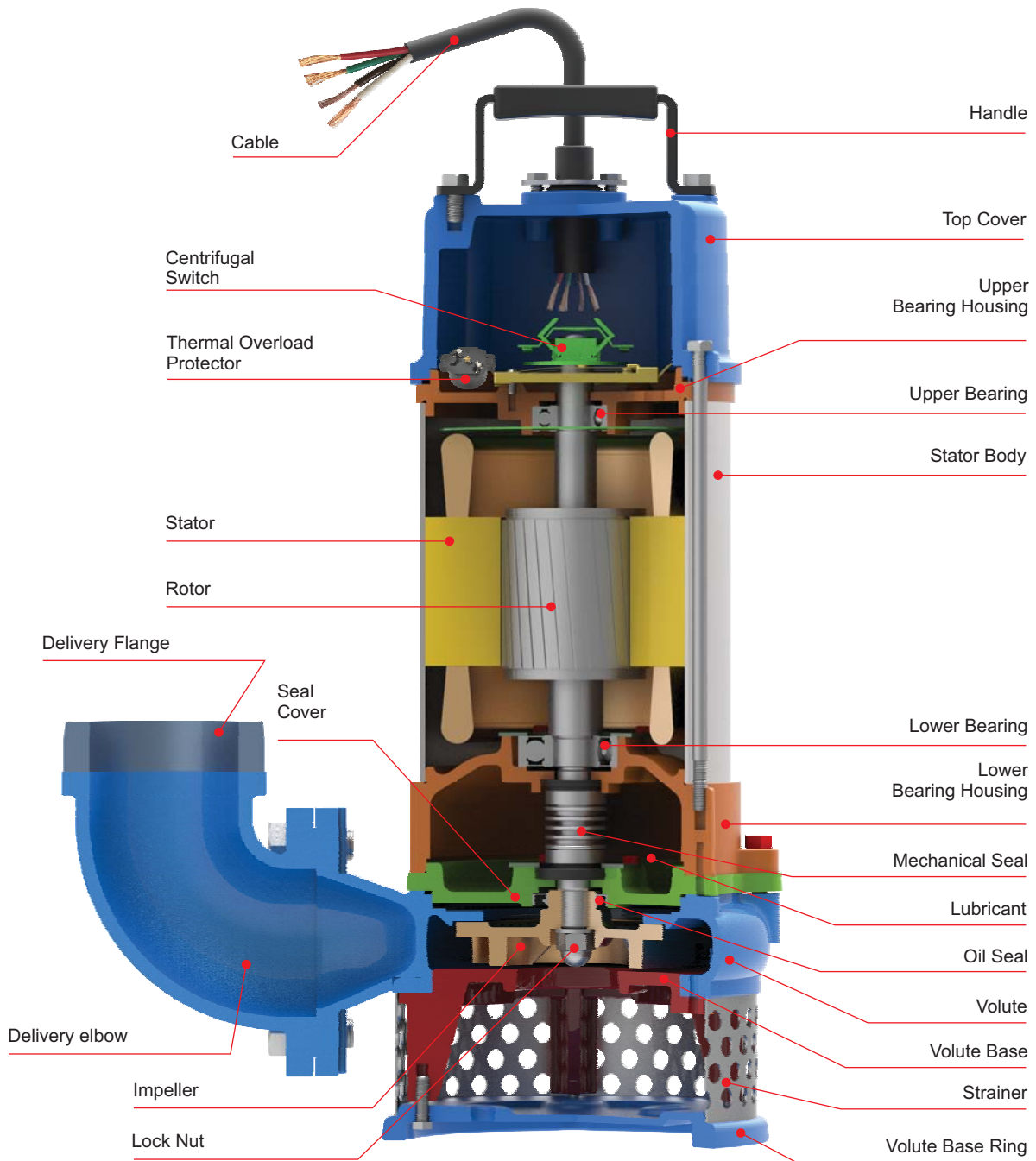

DRAINAGE PUMPS

GENERAL DATA

0.5 HP to 3.0 HP

General Pump Features

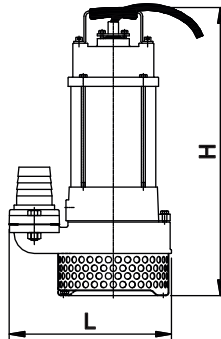

DIMENSIONS

Model		Disc. mm (inch)	Dimensions (mm)			Solid Passage mm	Net Weight (kg.)	Gross Weight (kg.)	Volume (m ³)	Cable data cable x core x size (mm ²) x length (m) x Material
Single Phase	Three Phase		Length	Width	Height					
ND-A-2015/2015F	-	50 (2")	230	161	365	8	15.0	17.0	0.032	1 x 3 x 1.0 x 5 x PVC
-	ND-A-2035/2035F		230	161	365		15.0	17.0	0.032	1 x 4 x 1.0 x 5 x PVC
ND-A-2115/2115F	-	50 (2")	277	178	440	10	19.0	21.0	0.045	1 x 3 x 1.0 x 5 x PVC
-	ND-A-2135/2135F		277	178	440		18.0	20.0	0.045	1 x 4 x 1.0 x 5 x PVC
ND-A-3215/3215F	-	80 (3")	412	208	569	11	44.0	69.0	0.146	1 x 3 x 2.0 x 8 x PVC
-	ND-A-3235/3235F		412	208	470		40.0	65.0	0.146	1 x 4 x 1.8 x 8 x PVC
ND-A-2315/2315F	-	50 (2")	280	216	572	11	46.0	70.0	0.146	1 x 3 x 3.5 x 8 x PVC
-	ND-A-2335/2335F		280	216	493		43.0	66.0	0.146	1 x 4 x 1.8 x 8 x PVC
ND-A-3315/3315F	-	80 (3")	385	216	575	11	47.0	71.0	0.146	1 x 3 x 3.5 x 8 x PVC
-	ND-A-3335/3335F		385	216	495		43.0	67.0	0.146	1 x 4 x 1.8 x 8 x PVC
ND-A-4315/4315F	-	100 (4")	390	208	584	11	47.0	72.0	0.146	1 x 3 x 3.5 x 8 x PVC
-	ND-A-4335/4335F		390	208	495		43.0	68.0	0.146	1 x 4 x 1.8 x 8 x PVC
ND-A-21A15/21A15F	-	50 (2")	277	178	470	10	22.0	25.5	0.050	1 x 3 x 1.5 x 5 x PVC
-	ND-A-21A35/21A35F		277	178	470		21.0	24.5	0.050	1 x 4 x 1.0 x 5 x PVC

PERFORMANCE CHART AT n = 2900 RPM FOR DRAINAGE PUMPS

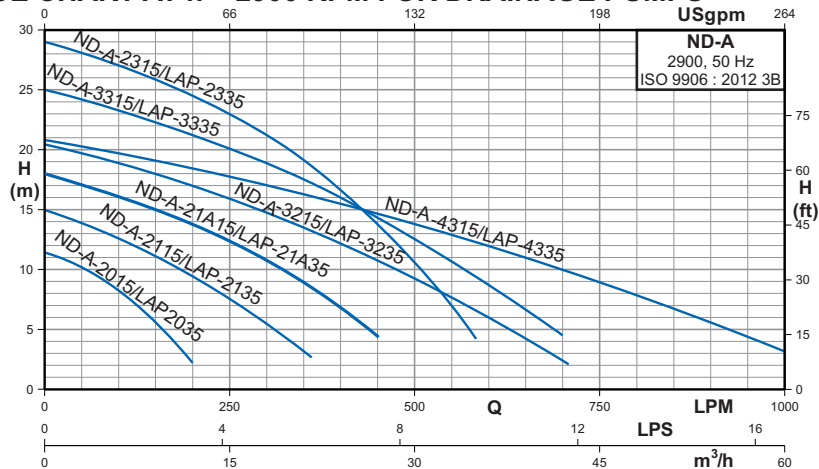

PERFORMANCE DATA AT n = 2900 RPM

Model		Power		Start Method	m ³ /h l/min.	6	9	12	18	24	30	36	45	54									
Single Phase	Three Phase	kW	HP			100	150	200	300	400	500	600	750	900									
ND-A-2015/2015F	-	0.37	0.5	Capacitor	H (m)	8.3	5.5	2.2	-	-	-	-	-	-									
-	ND-A-2035/2035F			Direct																			
ND-A-2115/2115F	-	0.75	1.0	Capacitor											12.5	11	9.4	5.5	-	-	-	-	-
-	ND-A-2135/2135F			Direct																			
ND-A-3215/3215F	-	1.50	2.0	Capacitor											19.9	18	17	14.8	12.2	9.2	6	-	-
-	ND-A-3235/3235F			Direct																			
ND-A-2315/2315F	-	2.20	3.0	Capacitor											27	26	24.5	21.2	16.6	10.5	-	-	-
-	ND-A-2335/2335F			Direct																			
ND-A-3315/3315F	-	2.20	3.0	Capacitor											23.3	22.3	21.2	18.9	16	12.5	9	-	-
-	ND-A-3335/3335F			Direct																			
ND-A-4315/4315F	-	2.20	3.0	Capacitor											19.7	19	18.4	17	15.5	13.8	12	9	5.5
-	ND-A-4335/4335F			Direct																			
ND-A-21A15/21A15F	-	1.10	1.5	Capacitor											16.0	15	13.8	10.7	6.9	-	-	-	-
-	ND-A-21A35/21A35F			Direct																			

Note : Subscript "F" pumps will be provided with a float switch.

SEWAGE PUMPS

GENERAL DATA 1.0 HP to 3.0 HP

Performance Range

- ▶ Flow rate up to 1000 l/min. (60 m³/h)
- ▶ Dynamic head up to 20 m.

Applications

- ▶ Drainage of sewage from the building basements, hotel industry, waste water from factories.
- ▶ Drainage of sewage from industrial process factories.
- ▶ Emptying fo septic tanks, cesspits and sewage pump stations.
- ▶ Pumping surface and drainage water from garages and sprinkler systems.

Features

- ▶ A precision manufactured motor is achieved utilizing a laminated sheet steel production process combined with the highest standard of quality control. The stator and wiring is impregnated with varnish and then heat dried in an industrial oven. This ensures a 100% quality manufactured motor with stable characteristics and a high efficiency.
- ▶ Standard accessories include: VCT cable with an epoxy resin sealed stainless steel cable base, AC thermal motor protector, dual mechanical seal and lip seal.

Special Features on Request

- ▶ Other voltages, Available in 60Hz.

Direction of Rotation

- ▶ Clockwise as seen from the motor rear end.

Thermal overload protector

- ▶ Equipped with Automatic reset motor protector, prevents motor from burning due to high temperature/phase failure/voltage drop and lock impeller.

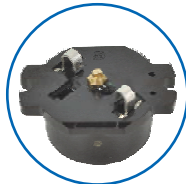

Cable base

- ▶ Epoxy resin seal cable base to prevent water intrusion into motor through the cable wire.

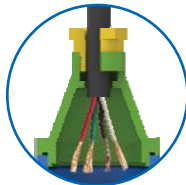

Specification

Pumping liquid	Diameter(mm)	50 - 80	
	Ambient temp	Max. +50°C	
	Liquid temp	0°C to +50°C	
Pump	Structure	Impeller	Semi - open
		M.seal	Double Mechanical seal
		Bearing	Ball type bearing
	Material	Impeller	Grey Iron
		Volute	Grey Iron
		Upper cover	Grey Iron
		Volute base	Grey Iron
	M.seal	Motor side	Carbon v/s Ceramic (0.75 - 2.2 kW)
		Pump side	Carbon v/s Ceramic (0.75 kW) Silicon Carbide v/s Silicon Carbide (1.5 - 2.2 kW)
	Motor	Insulation	F Class
Frequency		50 Hz	
Thermal Protector		Automatic reset motor protector	
Material		Stator body	S.S. AISI 304
		Shaft	S.S. AISI 410
		Cable	PVC
Protection	IP 68		
Duty	S1 - When pump is completely submerged. S3 - When pump is partially submerged.		
Voltage	1 Ph. 230 V +5%/-15%, 3 Ph. 400 V +5%/-15%		

P Type Impeller

- ▶ Semi-open impeller cutting foreign particles, and preventing clog by solid media.

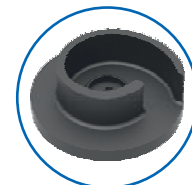

U Type Impeller

- ▶ This impeller can generate rapid rotating vortex to handle fluid mixed with long fiber, the majority of abrasive solids do not touch impeller to minimize impeller wear.

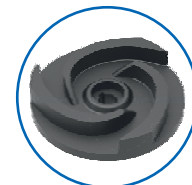

SEWAGE PUMPS

MATERIAL OF CONSTRUCTION 1.0 HP to 3.0 HP

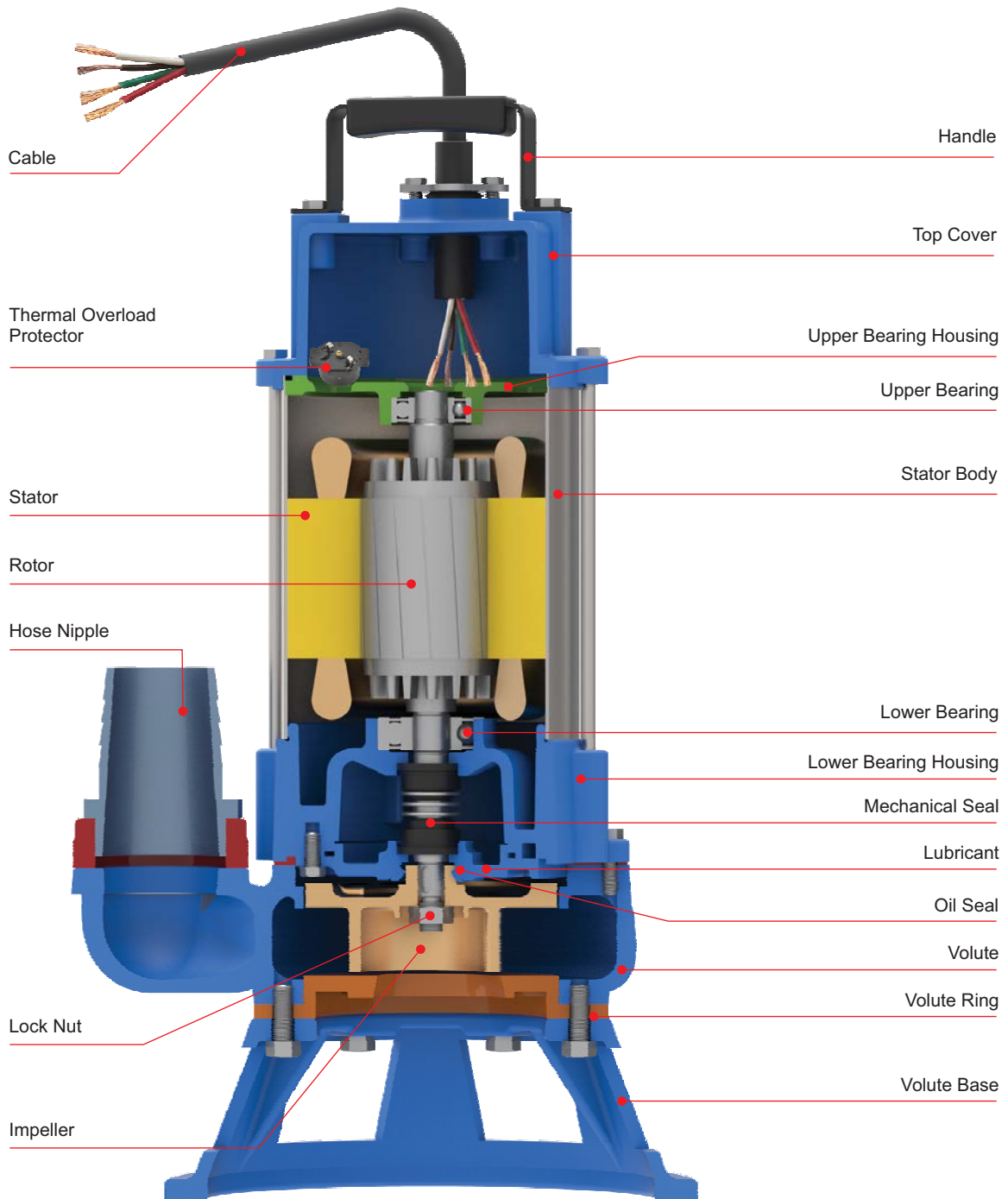

SEWAGE PUMPS

GENERAL DATA 1.0 HP to 3.0 HP

General Pump Features

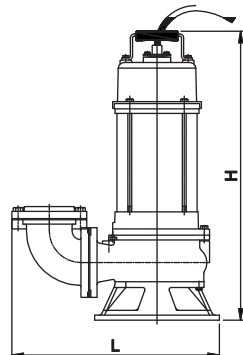

DIMENSIONS

Model		Disc. mm (Inch)	Impeller Type	Dimensions (mm)			Solid Passage (mm)	Net Weight (kg.)	Gross Weight (kg.)	Volume (m ³)	Cable data cable x core x size (mm ²) x length (m) x Material
Single Phase	Three Phase			Length	Width	Height					
ND-F-2115/2115F	-	50 (2")	P	304	235	475	23	21.0	23.0	0.072	1 x 3 x 1.0 x 5 x PVC
-	ND-F-2135/2135F			304	235	475		20.0	22.0	0.072	1 x 4 x 1.0 x 5 x PVC
ND-F-2115U/2115UF	-	50 (2")	U	265	192	455	35	21.0	23.0	0.072	1 x 3 x 1.0 x 5 x PVC
-	ND-F-2135U/2135UF			265	192	455		20.0	22.0	0.072	1 x 4 x 1.0 x 5 x PVC
ND-F-3215/3215F	-	80 (3")	P	432	260	600	32	44.0	71.0	0.179	1 x 3 x 2.0 x 8 x PVC
-	ND-F-3235/3235F			432	260	505		40.0	67.0	0.179	1 x 4 x 1.8 x 8 x PVC
ND-F-3315/3315F	-	80 (3")	P	432	260	620	35	48.0	73.0	0.179	1 x 3 x 3.5 x 8 x PVC
-	ND-F-3335/3335F			432	260	530		43.0	69.0	0.179	1 x 4 x 1.8 x 8 x PVC
ND-F-3215U/3215UF	-	80 (3")	U	408	258	610	15	44.0	71.0	0.179	1 x 3 x 2.0 x 8 x PVC
-	ND-F-3235U/3235UF			408	258	530		40.0	67.0	0.179	1 x 4 x 1.8 x 8 x PVC

PERFORMANCE CHART AT n = 2900 RPM FOR SEWAGE PUMPS

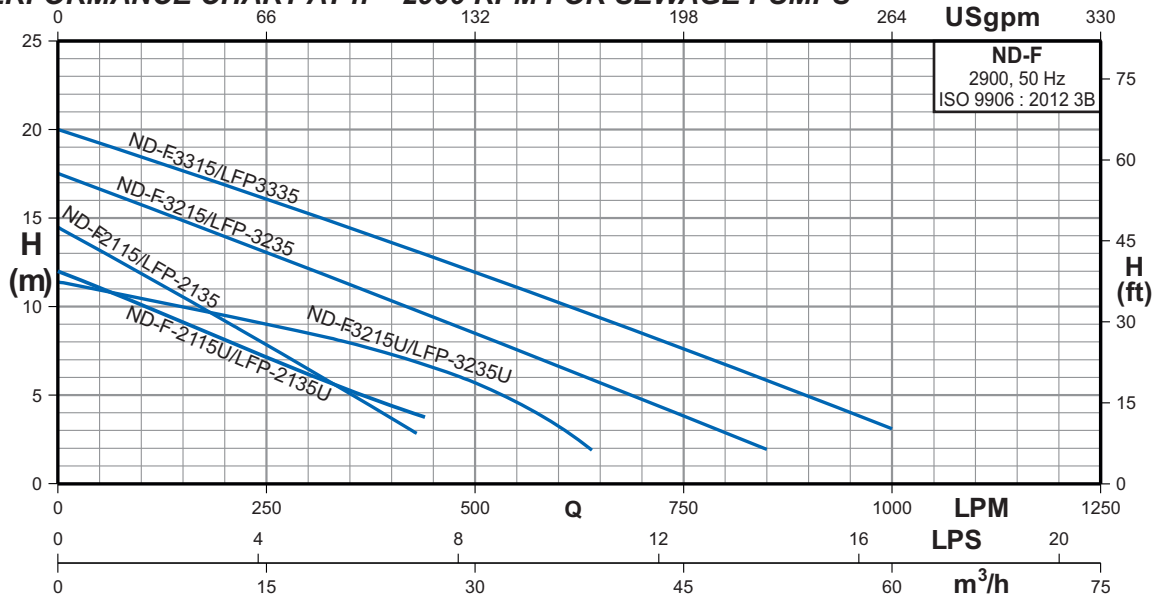

PERFORMANCE DATA AT n = 2900 RPM

Model		Power		Start Method	m ³ /h l/min.	3	6	12	18	24	36	48	60
Single Phase	Three Phase	kW	HP			50	100	200	300	400	600	800	1000
ND-F-2115/2115F	-	0.75	1.0	Capacitor	H (m)	13.2	12	9.2	6.5	3.7	-	-	-
-	ND-F-2135/2135F			Direct									
ND-F-2115U/2115UF	-	0.75	1.0	Capacitor		11	10.2	8.1	6.3	4.4	-	-	-
-	ND-F-2135U/2135UF			Direct									
ND-F-3215/3215F	-	1.50	2.0	Capacitor		16.6	15.8	14	12.1	10.3	6.5	2.9	-
-	ND-F-3235/3235F			Direct									
ND-F-3315/3315F	-	2.20	3.0	Capacitor		19.3	18.5	16.9	15.3	13.6	10.3	6.7	3.2
-	ND-F-3335/3335F			Direct									
ND-F-3215U/3215UF	-	1.50	2.0	Capacitor		10.9	10.5	9.5	8.5	7.3	3.2	-	-
-	ND-F-3235U/3235UF			Direct									

Note : Subscript "F" pumps will be provided with a float switch.

STAINLESS STEEL SUBMERSIBLE EFFLUENT VORTEX PUMPS

GENERAL DATA 1.0 HP to 3.0 HP

Performance Range

- ▶ Flow rate up to 450 l/min. (27 m³/h)
- ▶ Dynamic head up to 15 m.

Applications

- ▶ All applications of pumping and draining effluent, civil and industrial sewage with suspended solids.
- ▶ Pumping stations with one or more pumps for civil and industrial plants.

Features

- ▶ Light weight, portable.
- ▶ Made out of stainless steel AISI 304 sheet metal.
- ▶ High quality mechanical shaft seal.
- ▶ Class-F motor insulation which can handle higher motor temperature.
- ▶ Thermally protected motors which prevents motor from burn out.
- ▶ Vortex impeller designs to handle solids laden sewage and/or fibrous substance.
- ▶ A fully waterproof IP 68 structure, combined with a high grade silicon carbide mechanical seal.
- ▶ Permanently lubricated ball bearings.
- ▶ Solid passage size up to 40 mm.

Vortex Impeller



- ▶ Vortex impellers create a hydraulic passage, allowing long fibrous materials to pass through without any contact with the impeller.

Specification

Pumping liquid	Ambient temp	Max. +50°C	
	Liquid temp	0°C to +50°C	
	Liquid nature	Pumps are suitable for drainage waste or sump drainage water with or without solids.	
Pump	Structure	Impeller	Vortex
		M.seal	Mechanical seal
		Bearing	Ball type bearing
	Material	Impeller	S.S. AISI 304L
		Volute	S.S. AISI 304L
		Upper cover	S.S. AISI 304L
	M.seal	Sic/Sic	
Motor	Type		Dry motor
	Insulation		F Class
	Frequency		50 Hz
	Material	Stator body	S.S. AISI 304L
		Shaft	S.S. AISI 410
		Cable	PVC
Protection		IP 68	
Duty		S1 - When pump is completely submerged S3 - When pump is partially submerged	
Voltage		1 Ph. 230 V +5/-15%, 3 Ph. 400 V +5%/-15%	

Direction of Rotation

- ▶ Clockwise as seen from the motor rear end.

STAINLESS STEEL SUBMERSIBLE EFFLUENT VORTEX PUMPS

GENERAL DATA

1.0 HP to 3.0 HP

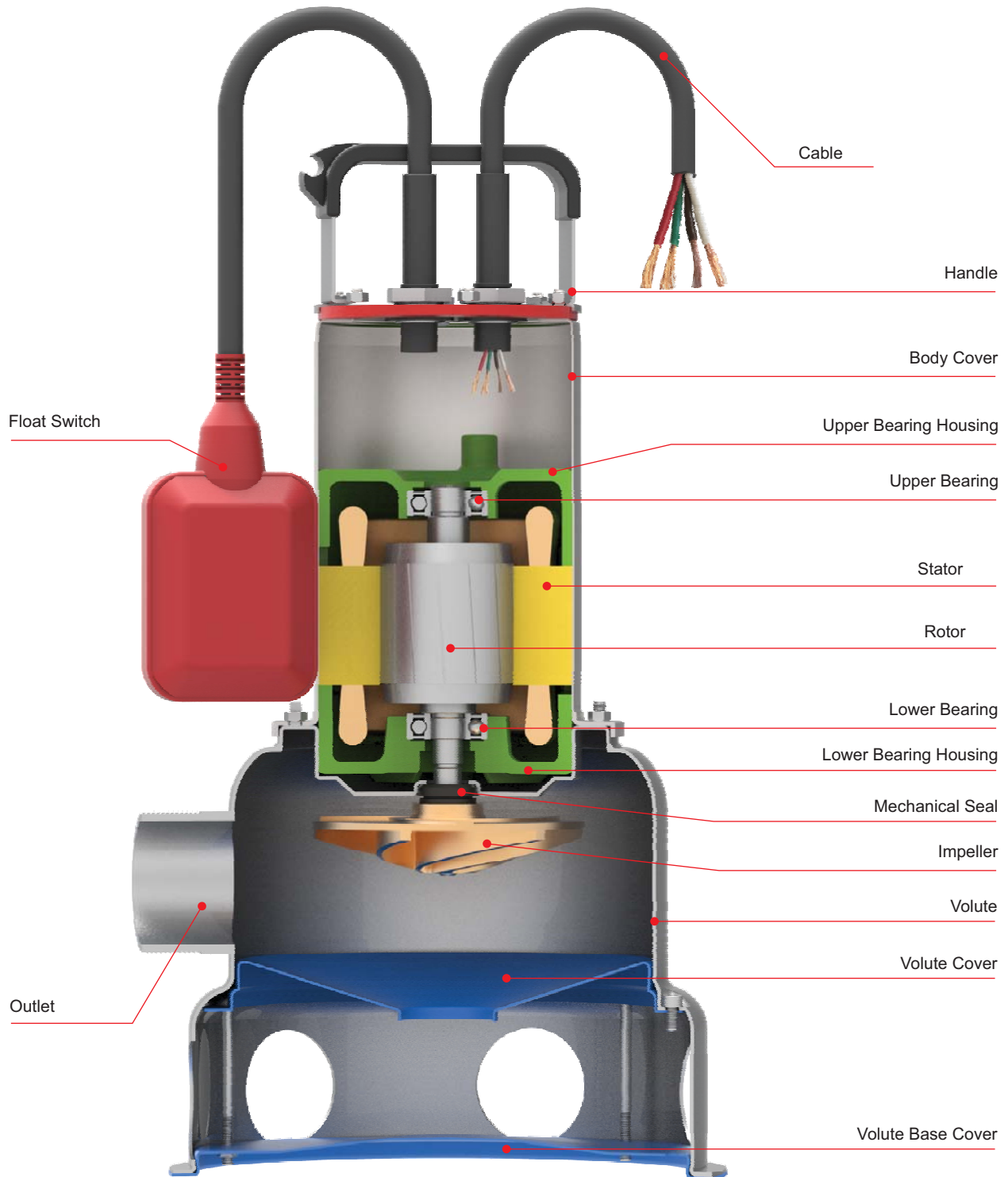

STAINLESS STEEL SUBMERSIBLE EFFLUENT VORTEX PUMPS

GENERAL DATA 1.0 HP to 3.0 HP

General Pump Features

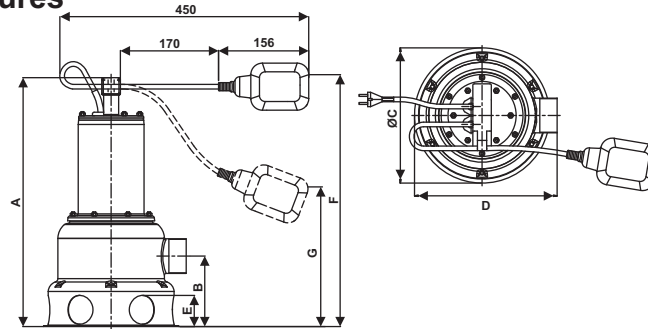

DIMENSIONS

Model		Disc. mm (Inch)	Dimensions (mm)							Net Weight (kg.)	Gross Weight (kg.)	Volume (m ³)	Cable data cable x core x size (mm ²) x length (m) x Material
Single Phase	Three Phase		A	B	C	D	E	F	G				
ND-B 2015F	-	50 (2")	430	123	235	241	55	550	290	9.5	11.8	0.045	1 x 3 x 1.0 x 5 x PVC
-	ND-B 2035/2035F	50 (2")	430	123	235	241	55	550	290	9.5	11.8	0.045	1 x 4 x 1.0 x 5 x PVC
ND-B 2115F	-	50 (2")	430	123	235	241	55	550	290	9.5	11.8	0.045	1 x 3 x 1.0 x 5 x PVC
-	ND-B 2135	50 (2")	430	123	235	241	55	550	290	10.5	13.0	0.045	1 x 4 x 1.0 x 5 x PVC
ND-B 21A15F	-	50 (2")	498	123	235	241	55	550	290	13.8	15.3	0.050	1 x 3 x 1.5 x 5 x PVC
ND-B 2215F	-	50 (2")	518	123	235	241	55	550	290	15.2	16.7	0.050	1 x 3 x 1.5 x 8 x PVC

PERFORMANCE CHART AT n = 2900 RPM FOR SS SUBMERSIBLE EFFLUENT VORTEX PUMPS

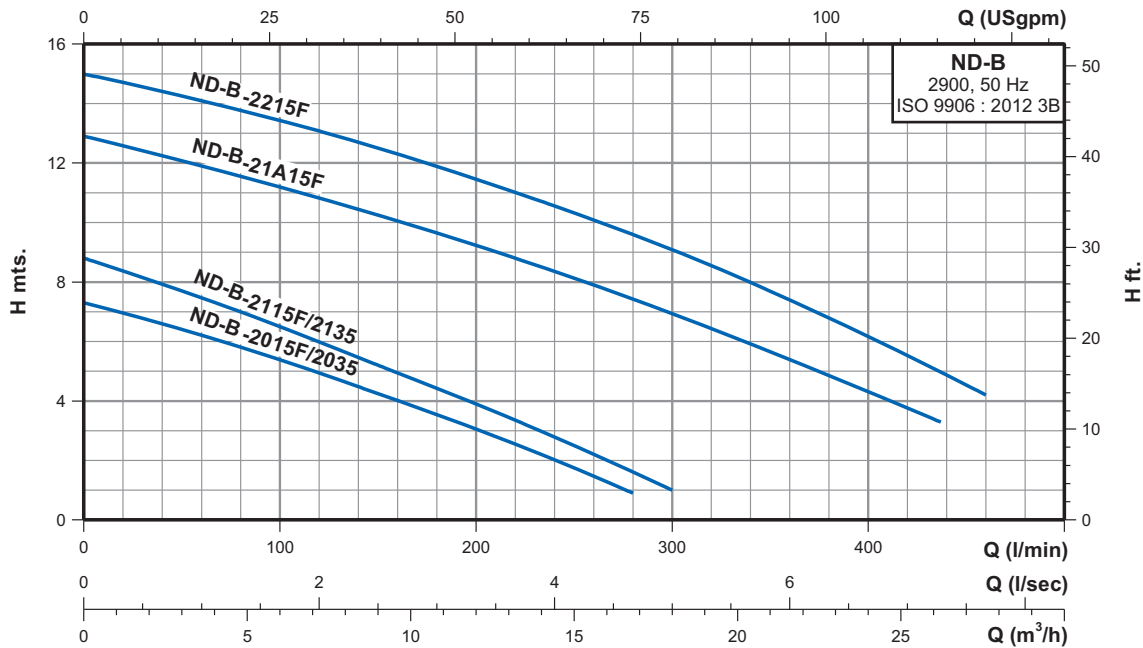

PERFORMANCE DATA AT n = 2900 RPM

MODEL		POWER		START METHOD	m ³ /h l/min	3	6	9	12	15	18	21	24	27
Single Phase	Three Phase	kW	HP			H (m)	50	100	150	200	250	300	350	400
ND-B 2015F	-	0.37	0.5	Capacitor	H (m)	6.4	5.4	4.3	3.1	1.7	-	-	-	-
-	ND-B 2035/2035F	0.37	0.5	Direct		6.4	5.4	4.3	3.1	1.7	-	-	-	-
ND-B 2115F	-	0.75	1.0	Capacitor		7.6	6.5	5.3	3.9	2.5	1	-	-	-
-	ND-B 2135	0.75	1.0	Direct		7.6	6.5	5.3	3.9	2.5	1	-	-	-
ND-B 21A15F	-	1.10	1.5	Capacitor		12	11.2	10.3	9.2	8.1	6.9	5.7	4.3	-
ND-B 2215F	-	1.50	2.0	Capacitor		14.3	13.4	12.5	11.5	10.4	9.1	7.7	6.1	4.6

Note : Subscript "F" pumps will be provided with a float switch.

HEAVY DUTY SEWAGE PUMPS

GENERAL DATA

5 HP TO 140 HP

Performance Range

- ▶ Flow rate up to 40000 l/min. (2400 m³/h)
- ▶ Dynamic head up to 49 m.

Applications

- ▶ Drainage of waste water from the liberation tank, purifying tank and sewage tank in water treatment plant.
- ▶ Drainage of waste water containing fibrous additives from leather factory, dyeing factory and food processing factory.
- ▶ Sewage management, accumulated water, septic tank, stock farm.
- ▶ Pumping sewage from single and multi family dwellings.
- ▶ Pumping sewage from hotels, restaurants, schools and public buildings.

Features

- ▶ International standard design : VCT cable, thermal overload protector, silicon carbide mechanical seal, high grade cast iron, good quality and performance.
- ▶ A water detector is provided in the seal chamber. In case of seal failure if water enters the seal chamber, a signal can be sent to the control panel so that the pump operator is made aware of a potential seal leakage problem.
- ▶ P / E Multiple impeller designs to handle solids laden sewage and/or fibrous substance.
- ▶ For Extra protection, an oil seal ring has been installed under the oil chamber. This lip seal helps prevent the ingress of silt and sand into the lower seal chamber.
- ▶ Superior abrasion resistant mechanical seal manufactured with silicon carbide to ensure the best seal effect.
- ▶ Full range offering low to high head and flow capabilities, with compact and easy installation. Also available with Guide Rail System, which allows automatic remote connection and disconnection without entering the pit.

Special Features on request

- ▶ Other Voltages, Available in 60Hz.

Direction of Rotation

- ▶ Clockwise as seen from the motor rear end.

Thermal overload protector

- ▶ Equipped with Automatic reset motor protector, prevents motor from burning due to high temperature/phase failure/voltage drop and lock impeller.



Miniature Thermal Protector

- ▶ Miniature Thermal Protector (MTP) is embedded in the windings of the motor. The MTP will transmit a signal to a control panel when windings temperature reaches a set point. This feature is available in 11 kW & above models only.

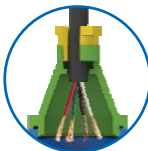

Cable base

- ▶ Epoxy resin seal cable base to prevent water intrusion into motor through the cable wire.

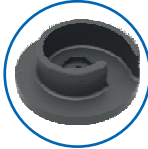

P Type Impeller

- ▶ Semi-open impeller enable cutting of delicate materials to prevent clogging.



Specification

Diameter(mm)		80 - 100 - 150	
Pumping liquid	Ambient temp	Max. +50°C	
	Liquid temp	0°C to +50°C	
	Liquid nature	Suitable for sewage waste water (with or without solids) from septic tanks, building basements and waste water form factories.	
Pump	Structure	Impeller	P type : semi - open, Non - clog E type : Enclosed single channel U type : Semi-vortex
		M.seal	Double mechanical seal
		Water detector	Installed in the seal chamber to detect water leakage from water infiltrating (5.5 kW and above)
	Bearing	Ball type bearing	
Material	Impeller	Grey Iron	
	Volute	Grey Iron	
	Upper cover	Grey Iron	
	Volute base ring	Grey Iron	
Mechanical seal	Motor side - Carbon v/s Ceramic Pump side - Silicon carbide v/s Silicon carbide		
Motor	Type	Dry motor	
	Insulation	F Class	
	Frequency	50 Hz	
	Thermal Protector	Automatic reset motor protector (up to 7.5 kW) Miniature Thermal Protector (11 kW & above)	
	Material	Stator body	Grey Iron
		Shaft	S.S. AISI 410
Cable		Thermoplastic Rubber/PVC	
Protection	IP 68		
Duty	S1 - When pump is completely submerged. S3 - When pump is partially submerged.		
Voltage	3 Ph. 400 V +5/-15%		

E Type Impeller

- ▶ Single channel non-clog impeller, allows large solids passage preventing clogging and allowing effective drainage/dewatering for higher head applications with solids laden media (for 7.5 kW to 55 kW).



U Type Impeller

- ▶ Vortex impellers create a hydraulic passage, allowing long fibrous materials to pass through without any contact with the impeller. Pump of U type impeller (3 Phase) operating in a higher current when reverse, please adjust into fit directions.

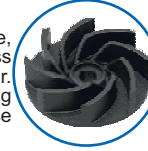

HEAVY DUTY SEWAGE PUMPS

GENERAL DATA

5 HP TO 140 HP

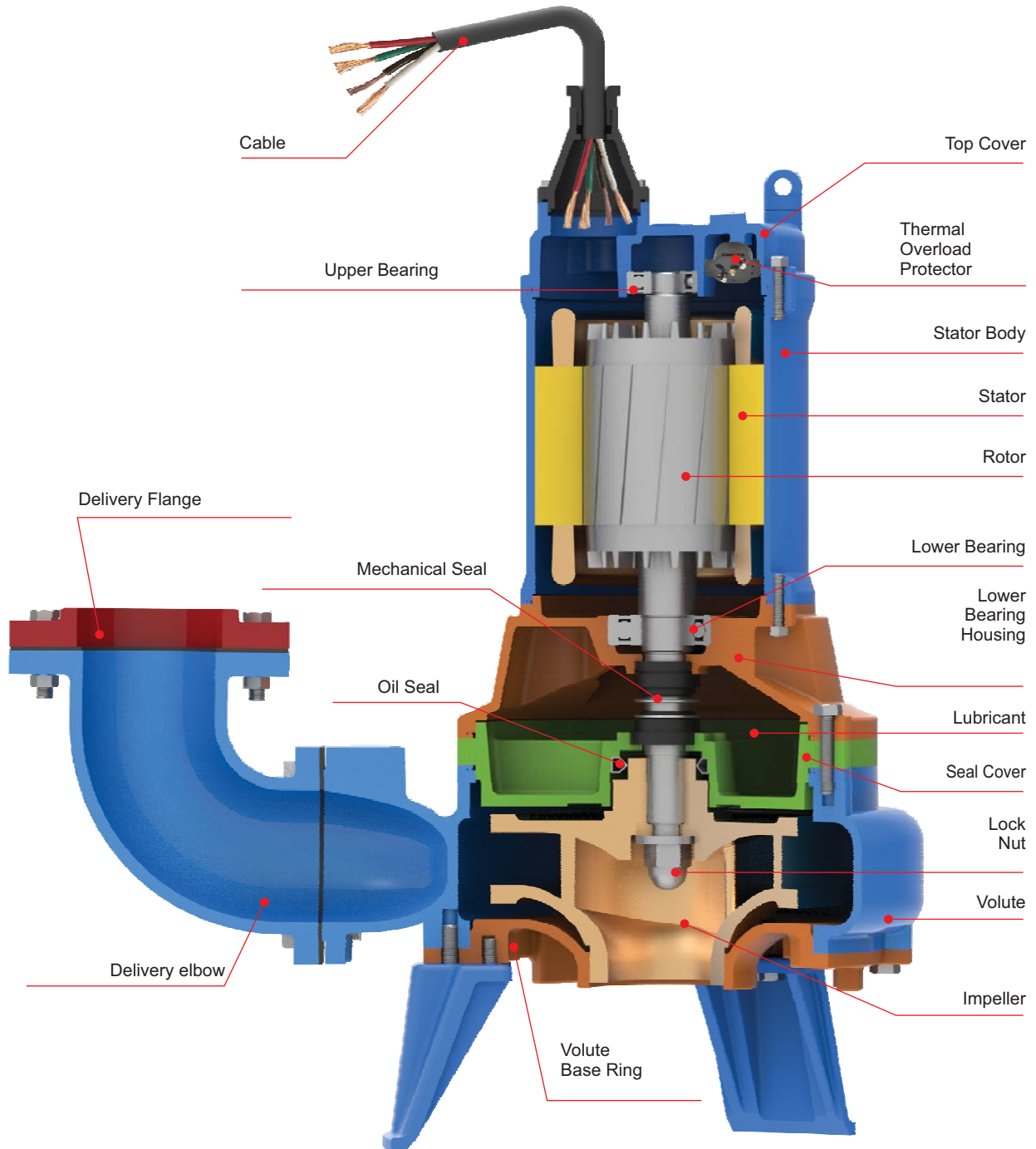

HEAVY DUTY SEWAGE PUMPS

GENERAL DATA

5 HP TO 140 HP

General Pump Features

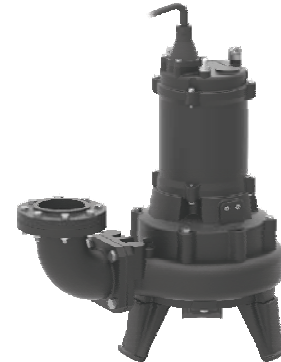
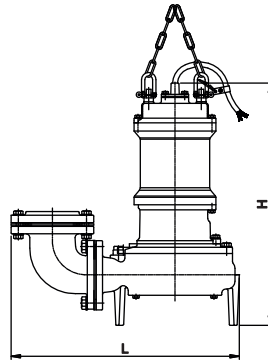

DIMENSIONS

Model	Phase	Disc. mm (Inch)	Impeller Type	Dimensions (mm)			Solid Passage (mm)	Net Weight (kg.)	Gross Weight (kg.)	Volume (m ³)	Cable data cable x core x size (mm ²) x length (m) x Material
				Length	Width	Height					
ND-H-3535U2	3Ø	80 (3")	U	480	220	595	56	58.0	93.0	0.186	1 x 4 x 1.8 x 8 x PVC
ND-H-3535	3Ø	80 (3")	P	580	310	650	50	82.0	127.0	0.288	1 x 4 x 1.8 x 8 x PVC
ND-H-3535U	3Ø	80 (3")	U	552	286	695	76	80.0	125.0	0.275	1 x 4 x 1.8 x 8 x PVC
ND-H-4535	3Ø	100 (4")	P	580	310	650	50	84.0	129.0	0.285	1 x 4 x 1.8 x 8 x PVC
ND-H-4735	3Ø	100 (4")	E	701	404	810	40	146.0	206.0	0.475	1 x 4 x 6.0 x 8 x PVC + 1 x 1 x 0.75 x 8 x PVC
ND-H-4735U	3Ø	100 (4")	U	701	404	810	65	143.0	203.0	0.475	1 x 4 x 6.0 x 8 x PVC + 1 x 1 x 0.75 x 8 x PVC
ND-H-41035	3Ø	100 (4")	E	701	404	850	40	163.0	213.0	0.495	1 x 4 x 6.0 x 8 x PVC + 1 x 1 x 0.75 x 8 x PVC
ND-H-61035	3Ø	150 (6")	E	850	472	905	70	230.0	317.0	0.663	1 x 4 x 6.0 x 8 x PVC + 1 x 1 x 0.75 x 8 x PVC

PERFORMANCE CHART AT n = 2900 RPM

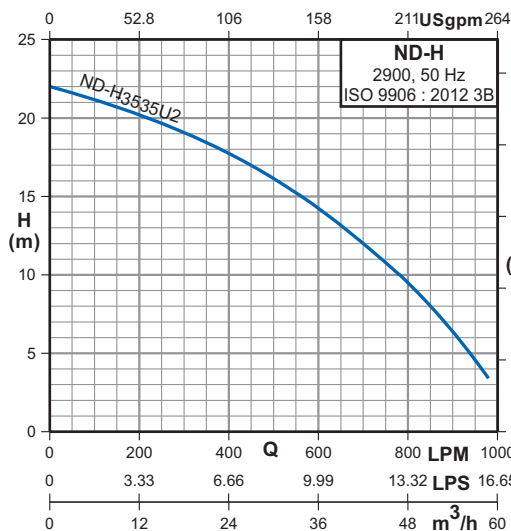

PERFORMANCE CHART AT n = 1450 RPM

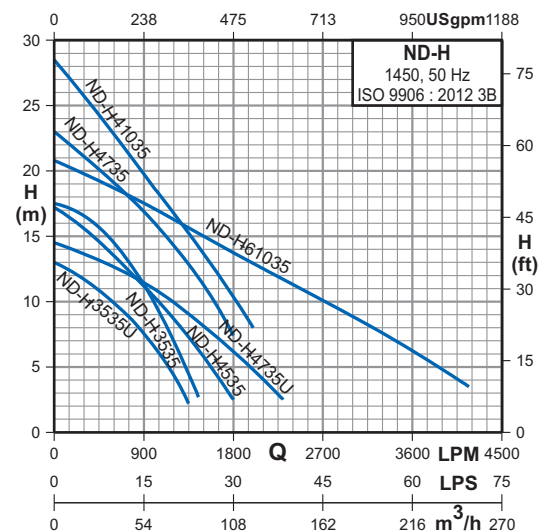

PERFORMANCE DATA AT n = 2900 RPM

Model	Phase	Power		Start Method	m ³ /h l/min.	6	12	18	24	30	36	42	48	54
		kW	HP			100	200	300	400	500	600	700	800	900
ND-H-3535U2	3Ø	3.7	5.0	Direct	H (m)	21.2	20.2	19	17.7	16.1	14.2	12	9.5	6.4

PERFORMANCE DATA AT n = 1450 RPM

Model	Phase	Power		Start Method	m ³ /h l/min.	12	24	36	48	54	60	90	120	150	180	210	240	246
		kW	HP			200	400	600	800	900	1000	1500	2000	2500	3000	3500	4000	4100
ND-H-3535	3Ø	3.7	5.0	Direct	H (m)	17	15.9	14.5	12.5	11.4	10	-	-	-	-	-	-	-
ND-H-3535U	3Ø	3.7	5.0	Direct		12.3	11	9.9	8.5	7.5	6.3	-	-	-	-	-	-	-
ND-H-4535	3Ø	3.7	5.0	Direct		16.2	14.8	13.5	12	11.1	10.2	5.8	-	-	-	-	-	-
ND-H-4735	3Ø	5.5	7.5	Direct		21.9	20.3	19	17.8	16.9	15.9	11.3	-	-	-	-	-	-
ND-H-4735U	3Ø	5.5	7.5	Direct		14	13.3	12.6	12	11.5	11	8.1	4.7	-	-	-	-	-
ND-H-41035	3Ø	7.5	10.0	Direct		26.7	24.5	22.7	20.8	19.7	18.5	13.6	8	-	-	-	-	-
ND-H-61035	3Ø	7.5	10.0	Direct		20.1	19.4	18.7	17.9	17.5	17	15	12.9	10.8	9	6.7	4.2	3.7

HEAVY DUTY SEWAGE PUMPS

GENERAL DATA

5 HP TO 140 HP

PERFORMANCE CHART AT n = 1450 RPM

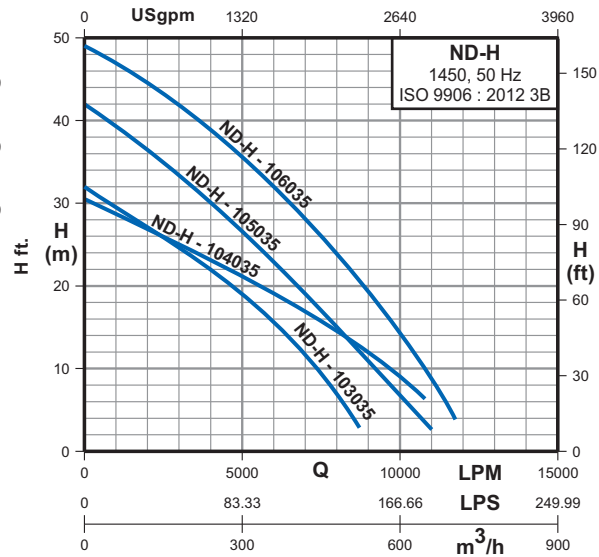
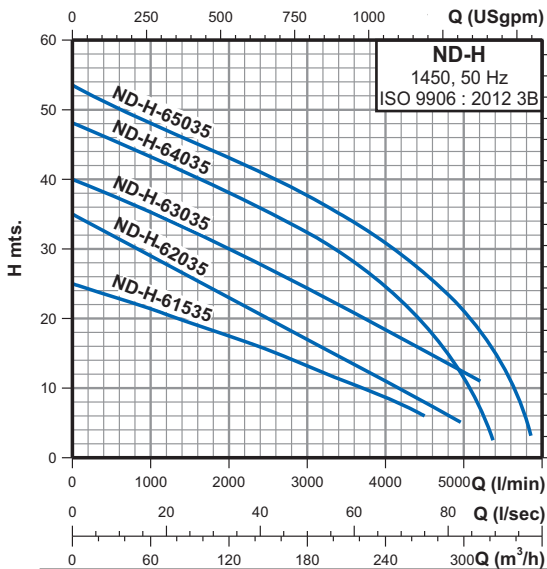

Model	Phase	Power		Start Method	m³/h	H (m)												
		kW	HP			60	120	150	180	240	270	300	360	420	480	540	600	660
ND-H-61535	3Ø	11.0	15.0	Y - Δ	60	21.8	17.5	15.4	13	8.7	-	-	-	-	-	-	-	-
ND-H-62035	3Ø	15.0	20.0	Y - Δ	120	29	23	20	17	11	8	-	-	-	-	-	-	-
ND-H-63035	3Ø	22.0	30.0	Y - Δ	150	35.3	30	27.2	24.1	18.3	15.3	12	-	-	-	-	-	-
ND-H-64035	3Ø	30.0	40.0	Y - Δ	180	43.3	38	35.3	32.4	24.5	19	11.5	-	-	-	-	-	-
ND-H-65035	3Ø	37.0	50.0	Y - Δ	240	48	43.1	40.6	37.6	30.9	26.4	21.1	-	-	-	-	-	-
ND-H-103035	3Ø	22.0	30.0	Y - Δ	270	29.5	27.2	26	24.7	22	20.6	19	15.7	11.8	7	-	-	-
ND-H-104035	3Ø	30.0	40.0	Y - Δ	300	29	27	26	25	23	22	21	19	17	15	12	9	-
ND-H-105035	3Ø	37.0	50.0	Y - Δ	360	39.2	36.5	35	33.4	30.2	28.3	26.7	22.8	19	15.2	11	6.7	2.8
ND-H-106035	3Ø	45.0	60.0	Y - Δ	420	47	44.6	43.2	41.9	38.8	37.3	35.5	32	28	23.7	19.2	14.1	8.7

PERFORMANCE CHART AT n = 1450 RPM

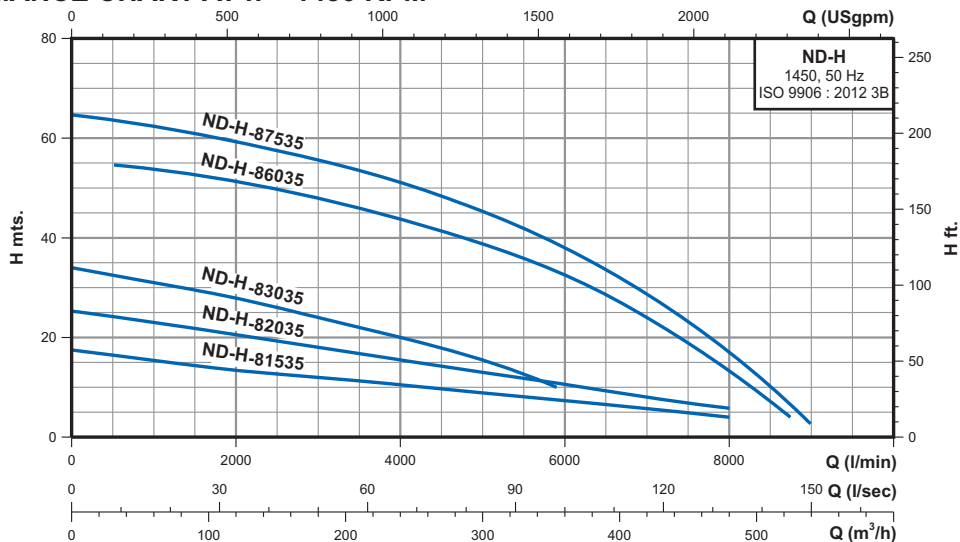

Model	Phase	Power		Start Method	m³/h	H (m)												
		kW	HP			30	60	90	120	150	180	210	240	270	300	360	420	480
ND-H-81535	3Ø	11.0	15.0	Y - Δ	30	16.5	15.4	14.6	13.4	12.8	12	11.3	10.5	9.6	9	-	-	-
ND-H-82035	3Ø	15.0	20.0	Y - Δ	60	24.2	23	21.9	20.6	19.4	18	16.8	15.5	14.2	13	7.3	5.5	3.9
ND-H-83035	3Ø	22.0	30.0	Y - Δ	90	32.6	31	29.4	27.9	26	24	22	20	17.9	15.5	10.6	8	5.9
ND-H-86035	3Ø	45.0	60.0	Y - Δ	120	-	53.8	52.7	51.3	49.8	47.9	46	43.8	41.4	38.6	32.6	24	13
ND-H-87535	3Ø	55.0	75.0	Y - Δ	150	63.6	62.4	60.8	59.1	57.4	55.5	53.6	51	48.2	45.1	38	28.5	17.1

HEAVY DUTY SEWAGE PUMPS

GENERAL DATA

5 HP TO 140 HP

PERFORMANCE CHART AT n = 1450 RPM

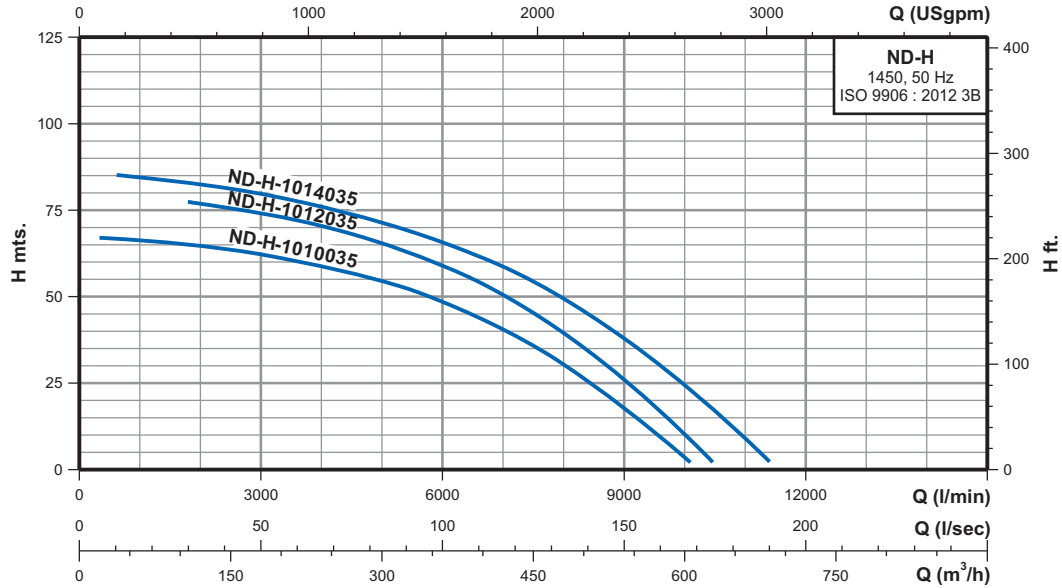

Model	Phase	Power		Start Method	m³/h l/min.	180	240	300	360	420	480	540	600	660
		kW	HP			3000	4000	5000	6000	7000	8000	9000	10000	11000
ND-H-1010035	3Ø	75.0	100.0	Y - Δ	H (m)	62.3	59	54.6	78.5	40.5	30.5	17.8	3.6	-
ND-H-1012035	3Ø	90.0	120.0	Y - Δ		74.1	70.5	65.4	58.7	50.4	39.5	25.5	10	-
ND-H-1014035	3Ø	104.0	140.0	Y - Δ		79.8	76	71.5	65.5	58.5	49.5	38	24.5	9

PERFORMANCE CHART AT n = 960 RPM

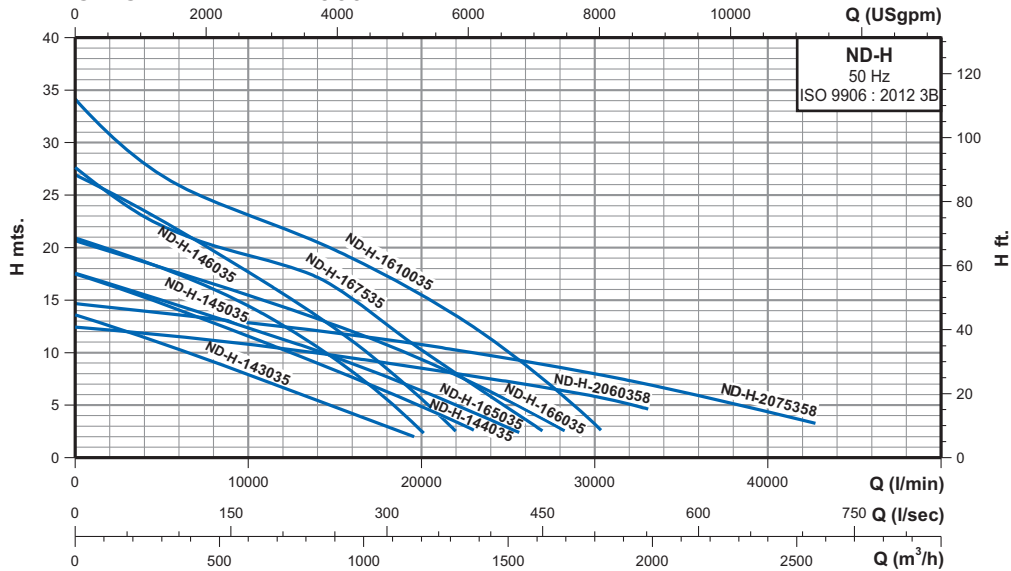

Model	Phase	Power		RPM	Start Method	m³/h l/min.	300	600	900	1200	1500	1800	2100	2400
		kW	HP				5000	10000	15000	20000	25000	30000	35000	40000
ND-H-143035	3Ø	22.0	30.0	960	Y - Δ	H (m)	11	8	4.8	-	-	-	-	-
ND-H-144035	3Ø	30.0	40.0	960	Y - Δ		14.7	11.6	8.3	4.8	-	-	-	-
ND-H-145035	3Ø	37.0	50.0	960	Y - Δ		18	14.5	9.3	2.5	-	-	-	-
ND-H-146035	3Ø	45.0	60.0	960	Y - Δ		22.6	17.7	12.3	5.6	-	-	-	-
ND-H-165035	3Ø	37.0	50.0	960	Y - Δ		15	12.4	9.7	6.4	2.8	2.8	-	-
ND-H-166035	3Ø	45.0	60.0	960	Y - Δ		18.1	15.5	12.6	9.5	5.4	5.4	-	-
ND-H-167535	3Ø	55.0	75.0	960	Y - Δ		22.1	19.3	16.3	10.3	4.5	-	-	-
ND-H-1610035	3Ø	75.0	100.0	960	Y - Δ		27	23	19.8	15.5	10.1	3.1	-	-
ND-H-2060358	3Ø	45.0	60.0	750	Y - Δ		11.7	10.8	9.7	8.5	7.2	5.8	-	-
ND-H-2075358	3Ø	55.0	75.0	750	Y - Δ		13.7	12.8	11.8	10.7	9.7	8.0	6.2	4.4

HEAVY DUTY SEWAGE PUMPS

GENERAL DATA

5 HP TO 140 HP

Figure 1

ND-H pumps with ring stand. (11 - 104 kW)

Note : (*) Minimum level for pump to operate on a continuous basis (S1 operation).

(**) Minimum acceptable liquid level of the pump. Pump should switch off at this level.

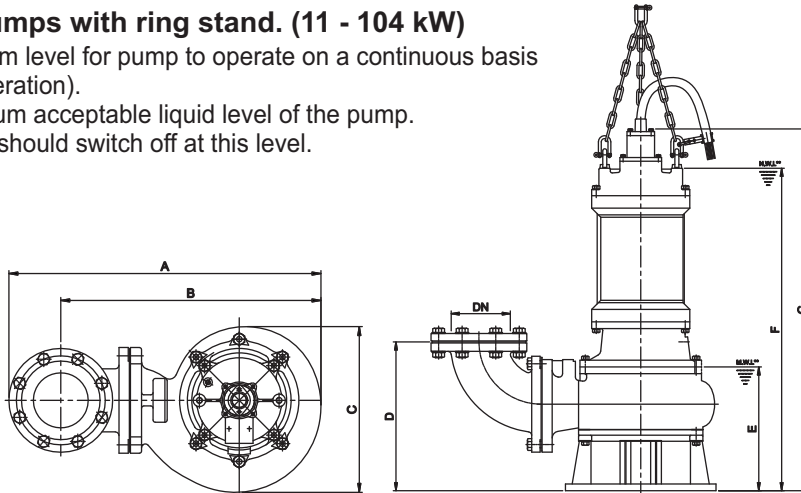

DIMENSIONS Figure 1

Model	Disc. Inch (mm)	Dimensions mm							Solid Passage (mm)	Net Weight (kg.)	Gross Weight (kg.)	Volume (m ³)
		A	B	C	D	E	F	G				
ND-H - 61535	6" (150)	848	705	472	442	367	958	1075	70	263	362	0.839
ND-H - 62035	6" (150)	809	666	450	387	330	885	1001	76	190	289	0.839
ND-H - 63035	6" (150)	850	707	496	400	348	878	945	76	232	361	0.824
ND-H - 64035	6" (150)	998	855	528	596	550	1271	1390	40	610	732	2.050
ND-H - 65035	6" (150)	998	855	528	596	550	1271	1390	40	640	768	2.050
ND-H - 81535	8" (200)	954	785	502	482	375	966	1084	75	277	389	0.999
ND-H - 82035	8" (200)	955	785	470	442	368	966	1080	75	285	397	0.999
ND-H - 83035	8" (200)	940	770	510	418	325	855	924	76	310	455	1.560
ND-H - 86035	8" (200)	1264	943	640	640	530	1402	1475	40	850	1020	2.15
ND-H - 87535	8" (200)	1264	943	640	640	530	1402	1475	40	900	1080	2.15
ND-H - 103035	10" (250)	1388	1186	640	740	552	1340	1395	60	745	929	2.211
ND-H - 104035	10" (250)	1388	1186	640	740	552	1340	1395	60	765	949	2.211
ND-H - 105035	10" (250)	1388	1186	640	740	552	1340	1395	60	770	954	2.211
ND-H - 106035	10" (250)	1388	1186	640	740	552	1340	1395	60	795	979	2.211
ND-H - 1010035	10" (250)	1477	1275	665	734	509	1458	1603	45	1180	1416	2.250
ND-H - 1012035	10" (250)	1477	1275	665	734	509	1458	1603	45	1220	1464	2.250
ND-H - 1014035	10" (250)	1477	1275	665	734	509	1458	1603	45	1250	1500	2.250
ND-H - 143035	14" (350)	1533	1255	785	824	630	1352	1409	120	870	1270	3.320
ND-H - 144035	14" (350)	1533	1255	785	824	630	1352	1409	120	880	1280	3.320
ND-H - 145035	14" (350)	1601	1324	805	824	640	1371	1428	90	1045	1445	3.320
ND-H - 146035	14" (350)	1601	1324	805	824	640	1371	1428	90	1085	1485	3.320
ND-H - 165035	16" (400)	1725	1415	859	875	655	1385	1443	120	1125	1585	3.710
ND-H - 166035	16" (400)	1725	1415	859	875	655	1385	1443	120	1165	1625	3.710
ND-H 167535	16" (400)	1767	1457	870	969	796	1602	1750	100	1540	1848	4.600
ND-H 1610035	16" (400)	1767	1457	870	969	796	1602	1750	100	1576	1891	4.600
ND-H - 2060358	20" (500)	2342	1977	1235	1130	856	1642	1789	140	2000	2400	7.250
ND-H - 2075358	20" (500)	2342	1977	1235	1130	856	1642	1789	140	2240	2688	7.250

Model	Cable data	
	cable x core x size (mm ²) x length (m) x Material	
ND-H - 61535	2 x 4 x 6.0 x 8 x PVC + 2 x 1 x 0.75 x 8 x PVC + 1 x 2 x 1.25 x 8 x Thermoplastic Rubber	
ND-H - 62035	2 x 4 x 6.0 x 8 x PVC + 2 x 1 x 0.75 x 8 x PVC + 1 x 2 x 1.25 x 8 x Thermoplastic Rubber	
ND-H - 63035	2 x 4 x 8.0 x 8 x Thermoplastic Rubber + 1 x 2 x 1.25 x 8 x Thermoplastic Rubber	
ND-H - 64035	2 x 4 x 10.0 x 8 x Thermoplastic Rubber + 1 x 2 x 1.25 x 8 x Thermoplastic Rubber	
ND-H - 65035	2 x 4 x 10.0 x 8 x Thermoplastic Rubber + 1 x 2 x 1.25 x 8 x Thermoplastic Rubber	
ND-H - 81535	2 x 4 x 6.0 x 8 x PVC + 2 x 1 x 0.75 x 8 x PVC + 1 x 2 x 1.25 x 8 x Thermoplastic Rubber	
ND-H - 82035	2 x 4 x 6.0 x 8 x PVC + 2 x 1 x 0.75 x 8 x PVC + 1 x 2 x 1.25 x 8 x Thermoplastic Rubber	
ND-H - 83035	2 x 4 x 10.0 x 8 x Thermoplastic Rubber + 1 x 2 x 1.25 x 8 x Thermoplastic Rubber	
ND-H 86035	2 x 4 x 25.0 x 8 x Thermoplastic Rubber + 1 x 2 x 1.25 x 8 x Thermoplastic Rubber	
ND-H 87535	2 x 4 x 25.0 x 8 x Thermoplastic Rubber + 1 x 2 x 1.25 x 8 x Thermoplastic Rubber	
ND-H - 103035	2 x 4 x 10.0 x 8 x Thermoplastic Rubber + 1 x 2 x 1.25 x 8 x Thermoplastic Rubber	
ND-H - 104035	2 x 4 x 8.0 x 8 x Thermoplastic Rubber + 1 x 2 x 1.25 x 8 x Thermoplastic Rubber	
ND-H - 105035	2 x 4 x 10.0 x 8 x Thermoplastic Rubber + 1 x 2 x 1.25 x 8 x Thermoplastic Rubber	
ND-H - 106035	2 x 4 x 10.0 x 8 x Thermoplastic Rubber + 1 x 2 x 1.25 x 8 x Thermoplastic Rubber	
ND-H - 1010035	2 x 4 x 35.0 x 8 x Thermoplastic Rubber + 1 x 2 x 1.25 x 8 x Thermoplastic Rubber	
ND-H - 1012035	2 x 4 x 35.0 x 8 x Thermoplastic Rubber + 1 x 2 x 1.25 x 8 x Thermoplastic Rubber	

Model	Cable data	
	cable x core x size (mm ²) x length (m) x Material	
ND-H - 1014035	2 x 4 x 35.0 x 8 x Thermoplastic Rubber + 1 x 2 x 1.25 x 8 x Thermoplastic Rubber	
ND-H - 143035	2 x 4 x 10.0 x 8 x Thermoplastic Rubber + 1 x 2 x 1.25 x 8 x Thermoplastic Rubber	
ND-H - 144035	2 x 4 x 10.0 x 8 x Thermoplastic Rubber + 1 x 2 x 1.25 x 8 x Thermoplastic Rubber	
ND-H - 145035	2 x 4 x 10.0 x 8 x Thermoplastic Rubber + 1 x 2 x 1.25 x 8 x Thermoplastic Rubber	
ND-H - 146035	2 x 4 x 10.0 x 8 x Thermoplastic Rubber + 1 x 2 x 1.25 x 8 x Thermoplastic Rubber	
ND-H - 165035	2 x 4 x 10.0 x 8 x Thermoplastic Rubber + 1 x 2 x 1.25 x 8 x Thermoplastic Rubber	
ND-H - 166035	2 x 4 x 10.0 x 8 x Thermoplastic Rubber + 1 x 2 x 1.25 x 8 x Thermoplastic Rubber	
ND-H 167535	2 x 4 x 25.0 x 8 x Thermoplastic Rubber + 1 x 2 x 1.25 x 8 x Thermoplastic Rubber	
ND-H 1610035	2 x 4 x 25.0 x 8 x Thermoplastic Rubber + 1 x 2 x 1.25 x 8 x Thermoplastic Rubber	
ND-H - 2060358	2 x 4 x 25.0 x 8 x Thermoplastic Rubber + 1 x 2 x 1.25 x 8 x Thermoplastic Rubber	
ND-H - 2075358	2 x 4 x 25.0 x 8 x Thermoplastic Rubber + 1 x 2 x 1.25 x 8 x Thermoplastic Rubber	

HEAVY DUTY SEWAGE PUMPS

GENERAL DATA

5 HP TO 140 HP

Figure 2

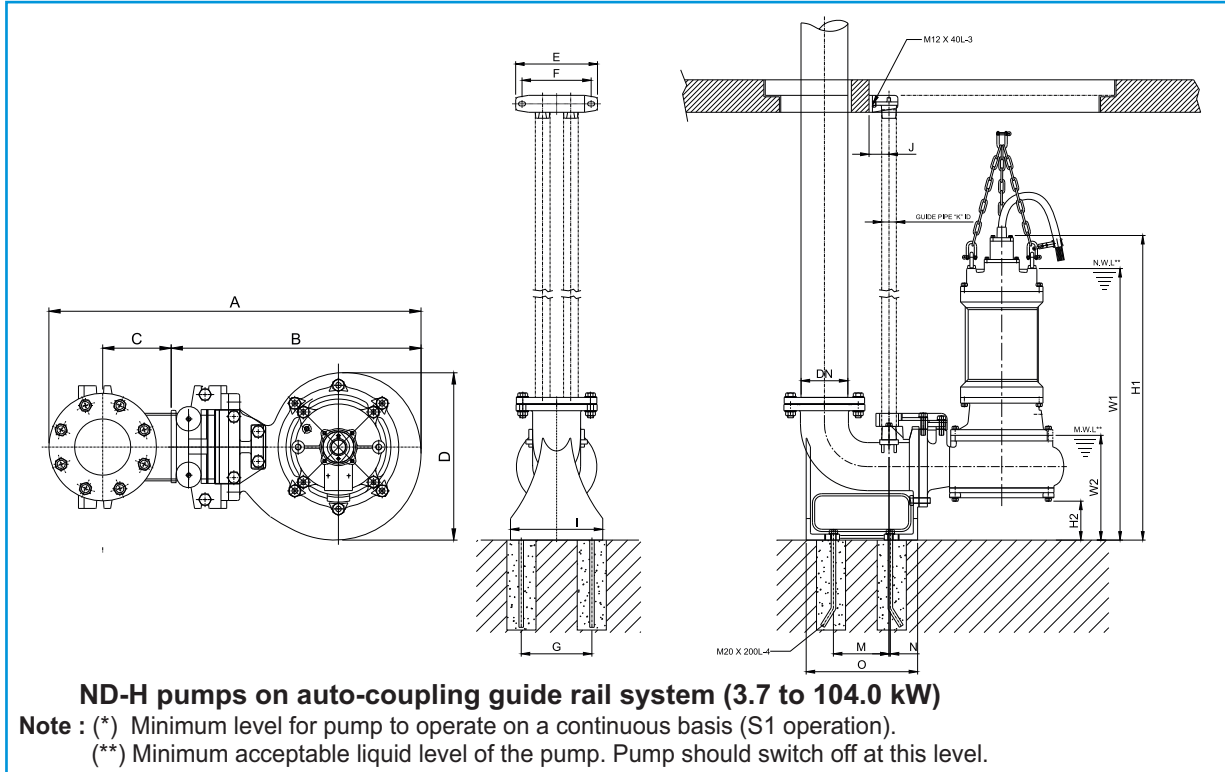

DIMENSIONS Figure 2

Model	Disc. Inch	Dimensions mm																
Three Phase	(mm)	A	B	C	D	E	F	G	I	J	K***	M	N	O	W1	W2	H1	H2
ND-H - 3535U2	3" (80)	698	454	150	216	290	245	200	247	70	50	158	22	270	604	259	670	75
ND-H - 3535	3" (80)	765	521	150	285	290	245	200	247	70	50	158	22	270	658	295	728	31
ND-H - 3535U	3" (80)	765	521	150	285	290	245	200	247	70	50	158	22	270	658	295	728	31
ND-H - 4535	4" (100)	812	536	170	315	290	245	200	247	70	50	178	22	285	650	260	718	75
ND-H - 4735	4" (100)	905	630	170	385	290	245	200	247	70	50	178	22	285	695	295	791	124
ND-H - 4735U	4" (100)	905	630	170	385	290	245	200	247	70	50	178	22	285	695	295	791	124
ND-H - 41035	4" (100)	905	630	170	385	290	245	200	247	70	50	178	22	285	735	295	831	124
ND-H - 61035	6" (150)	992	710	140	446	340	295	280	327	90	50	235	44	400	810	370	907	168
ND-H - 61535	6" (150)	992	710	140	446	340	295	280	327	90	50	235	44	400	980	370	1070	168
ND-H - 62035	6" (150)	1022	710	170	450	290	245	280	325	70	50	260	20	370	927	351	1015	22
ND-H - 63035	6" (150)	1060	750	170	496	290	245	280	325	70	50	260	20	370	906	358	947	10
ND-H - 64035	6" (150)	1145	806	196	528	340	295	280	327	90	50	280	44	400	1121	385	1240	150
ND-H - 65035	6" (150)	1145	806	196	528	340	295	280	327	90	50	280	44	400	1121	385	1240	150
ND-H - 81535	8" (200)	1064	662	230	502	300	175	320	350	95	50	269	41	400	984	393	1102	18
ND-H - 82035	8" (200)	1161	760	230	497	340	295	320	350	90	50	233	36	446	1008	397	1098	188
ND-H - 83035	8" (200)	1280	885	230	510	320	280	280	350	100	40	200	80	370	891	361	960	36
ND-H 86035	8" (200)	1448	1010	268	640	340	295	320	350	90	50	300	65	426	1280	408	1353	152
ND-H 87535	8" (200)	1448	1010	268	640	340	295	320	350	90	50	300	65	426	1280	408	1353	152
ND-H - 103035	10" (250)	1591	1118	270	624	420	350	360	460	110	65	310	74	560	1185	447	1225	198
ND-H - 104035	10" (250)	1591	1118	270	624	420	350	360	460	110	65	310	74	560	1185	447	1225	198
ND-H - 105035	10" (250)	1650	1176	270	640	420	350	360	460	110	65	310	74	560	1185	447	1225	195
ND-H - 106035	10" (250)	1650	1176	270	640	420	350	360	460	110	65	310	74	560	1185	447	1225	195
ND-H - 1010035	10" (250)	1738	1200	335	665	420	350	360	460	110	65	385	120	560	1362	413	1508	206
ND-H - 1012035	10" (250)	1738	1200	335	665	420	350	360	460	110	65	382	120	560	1362	413	1508	206
ND-H - 1014035	10" (250)	1738	1200	335	665	420	350	360	460	110	65	385	120	560	1362	413	1508	206
ND-H - 143035	14" (350)	1892	1315	305	785	610	510	580	700	220	114	601.5	89.5	950	1424	703	1481	372
ND-H - 144035	14" (350)	1892	1315	305	785	610	510	580	700	220	114	601.5	89.5	950	1424	703	1481	372
ND-H - 145035	14" (350)	1961	1374	305	805	610	510	580	700	220	114	602	90	950	1443	712	1500	372
ND-H - 146035	14" (350)	1961	1374	305	805	610	510	580	700	220	114	602	90	950	1443	712	1500	372
ND-H - 165035	16" (400)	2116	1433	373	859	610	510	580	700	220	114	602	90	950	1460	729	1517	372
ND-H - 166035	16" (400)	2116	1433	373	859	610	510	580	700	220	114	602	90	950	1460	729	1517	372
ND-H-167535	16"(400)	2167	1251	1285	466	610	510	580	700	220	114	691	129.5	950	1580	773	1726	375
ND-H-1610035	16"(400)	2167	1251	1285	466	610	510	580	700	220	114	691	129.5	950	1580	773	1726	375
ND-H - 2060358	20" (500)	2742	1649	508	1235	610	510	580	700	220	114	590	6.5	850	943	865	1799	385
ND-H - 2075358	20" (500)	2742	1649	508	1235	610	510	580	700	220	114	590	6.5	850	943	865	1799	385

*** Customer scope of supply as per actual site condition.

GRINDER PUMP

GENERAL DATA

2 HP TP 5 HP

Performance Range

- ▶ Flow rate up to 325 l/min. (19.5 m³/h)
- ▶ Dynamic head up to 32 m.

Applications

- ▶ Used in pressure sewage system.
- ▶ Drainage of waste water from individual residences, apartment, buildings, recreational developments, motels.
- ▶ Transferring waste water of commercial buildings, industrial plants, waste water sampling, small hospitals.
- ▶ Schools, federal, state and local parks' waste water drainage.
- ▶ To transfer various waste water and sewage.

Features

- ▶ Durable heavy duty finned cast iron construction.
- ▶ Grinder is complete unit, light weight, compact, and portable, easy to be installed.
- ▶ Double protection at connection box: barrier grommet, barrier epoxy, prevent water ingress to the motor area, assuring a longterm reliable operation. Additionally, epoxy encapsulation and stripped leads positively eliminate wicking from the cable.
- ▶ Two balls bearing construction support shaft and rotor.
- ▶ Dry type motor with high efficiency and low current. Equipped with auto reset motor protector, prevent the motor damage from abnormal heat and current.
- ▶ The dual silicon carbide mechanical seal system and extra oil seal protection protects the motor from sewage contamination, to provide you exceptionally long pump service life.
- ▶ An excellent vortex impeller and casing water cavity housing design. Provide high efficiency and power saving, handling ground slurry and sewage without clogging or binding.
- ▶ Radial cutter and cutter ring: corrosion resistant material, hardened to 55 - 60 Rockwell C.

Direction of Rotation

- ▶ Clockwise as seen from the motor rear end.

Cutting Ability Demonstration

- ▶ Specialized one single strong shaft with impeller and radial cutter, dramatically reduces the torque requirement on the motor, cuts with less horsepower, and increases the pump's efficiency. What's more, it prevents clogging with some troublesome objects such as sanitary napkins, plastic, rubber, disposable diapers and cloth items. The design of Northam grinder prevents clogging, binding and roping. They chop up almost anything and everything in order for you to get a continuous, long - term pumping service.

Specification

Horse Power		2, 3, 5 HP	
Pumping liquid	Ambient temp	Max. +50°C	
	Liquid temp	0°C to +50°C	
	Liquid nature	Suitable for pumping waste water of commercial buildings, hotels & restaurants, hospitals, industrial plants & kitchen waste.	
Pump	Construction	Impeller	Vortex
		Cutting Cons.	Grinding
		Mech. seal	Double Mechanical seal
		Upper Bearing	Ball Bearing
		Lower Bearing	Two ball Bearings
	Material	Impeller	Grey Iron
		Volute	Grey Iron
		Radial Cutter	S.S AISI 440
		Cutter Ring	S.S AISI 440
		Mechanical seal	Motor side - Carbon v/s Ceramic Pump side - Silicon carbide v/s Silicon carbide
Motor	Type	Dry motor	
	Insulation	F Class	
	Frequency	50 Hz	
	Thermal Protector	Automatic reset motor protector	
	Material	Stator body	Grey Iron
		Shaft	S.S AISI 410
		Cable	PVC
Protection	IP 68		
Duty	S1 - When pump is completely submerged. S3 - When pump is partially submerged.		
Voltage	1 Ph. 230 V +5/-15%, 3 Ph. 400 V +5/-15%		

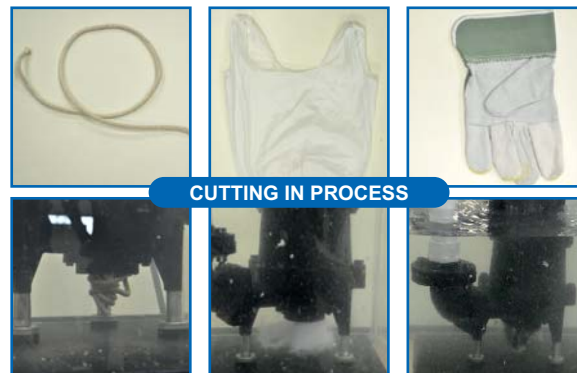

GRINDER PUMP

GENERAL DATA

2 HP TP 5 HP

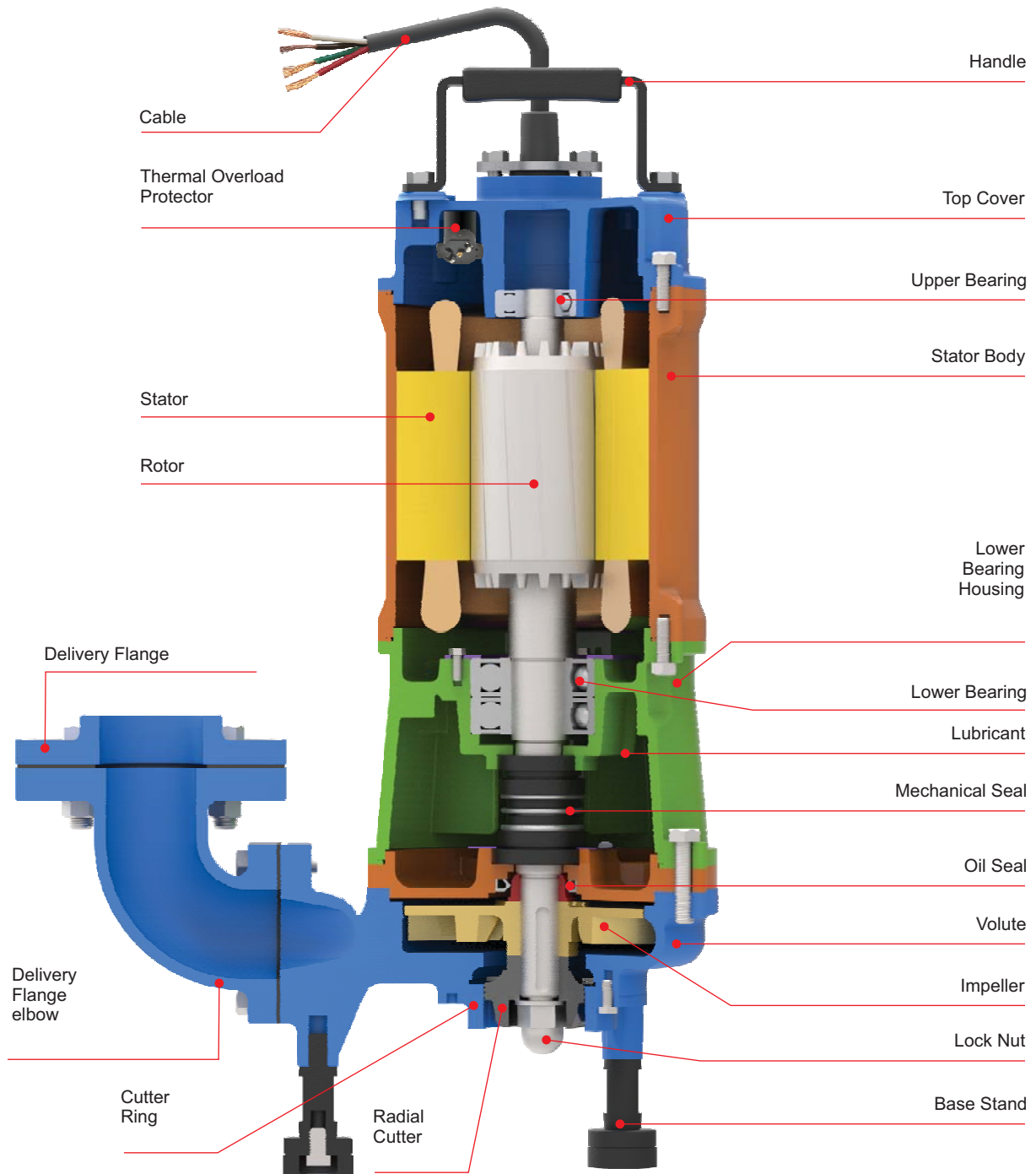

GRINDER PUMP

GENERAL DATA

2 HP TP 5 HP

General Pump Features

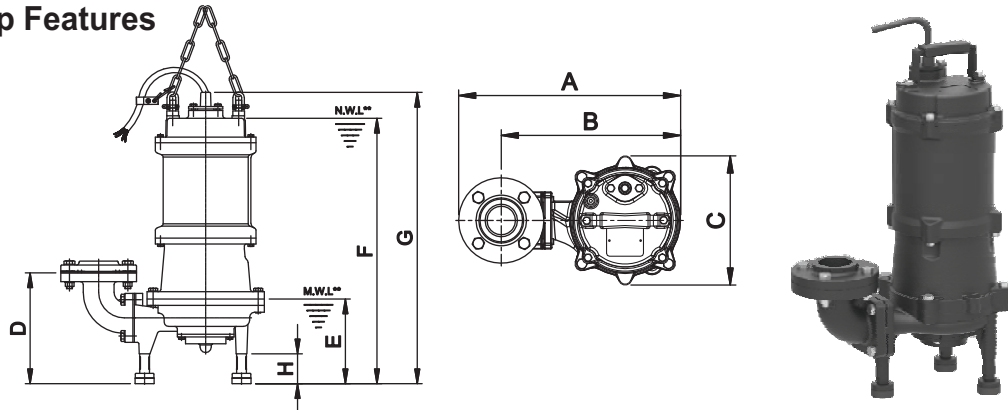

DIMENSIONS

Type	PHASE	DN	DIMENSIONS (MM)								NET WEIGHT (kg.)	GROSS WEIGHT (kg.)	VOLUME (m ³)	CABLE DATA cable x core x size (mm ²) x length (m) x Material
			A	B	C	D	E	F	G	H				
ND-G-1215/1215F	1Ø	32	286	250	203	156	160	543	610	61	38.0	70.0	0.126	1 x 3 x 2.0 x 8 x PVC
ND-G-1235/1235F	3Ø	32	286	250	203	156	160	492	556	61	34.0	64.0	0.117	1 x 4 x 1.8 x 8 x PVC
ND-G-1315/1315F	1Ø	32	286	250	203	156	160	543	610	61	40.0	72.0	0.126	1 x 3 x 3.5 x 8 x PVC
ND-G-1335/1335F	3Ø	32	286	250	203	156	160	492	556	61	36.0	66.0	0.117	1 x 4 x 1.8 x 8 x PVC
ND-G-2335	3Ø	50	416	339	195	226	160	522	593	61	51.0	86.0	0.156	1 x 4 x 1.8 x 8 x PVC
ND-G-2535	3Ø	50	416	339	195	226	160	543	616	61	54.0	89.0	0.161	1 x 4 x 1.8 x 8 x PVC

All Dimensions in mm

PERFORMANCE CHART AT n = 2900 RPM FOR GRINDER PUMPS

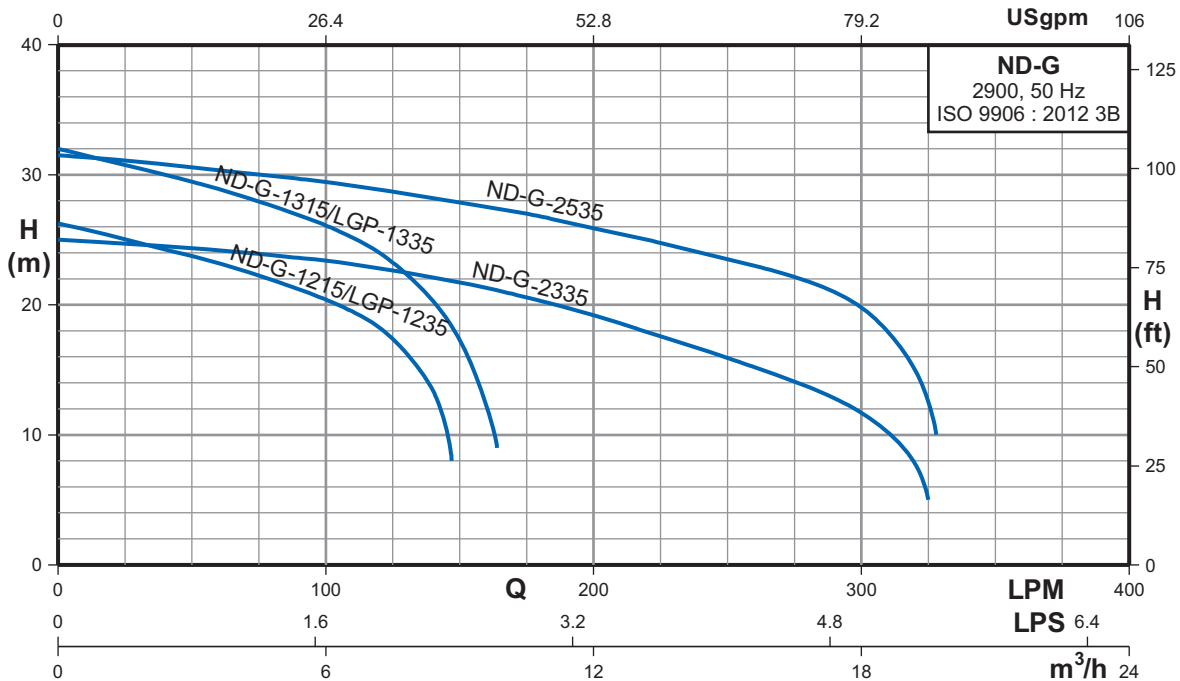

PERFORMANCE DATA AT n = 2900 RPM

Model	Phase	Power		Start Method	m ³ /h l/min.	1.5	3	4.5	6	7.5	9	12	15	18	19.5	
		kW	HP			25	50	75	100	125	150	200	250	300	325	
ND-G-1215/1215F	1Ø	1.5	2.0	Capacitor	H(m)	25	23.9	22.2	20.5	17.3	-	-	-	-	-	
ND-G-1235/1235F	3Ø			Direct												
ND-G-1315/1315F	1Ø	2.2	3.0	Capacitor		30.8	29.4	28	26	23.2	17.2	-	-	-	-	-
ND-G-1335/1335F	3Ø			Direct												
ND-G-2335	3Ø	2.2	3.0	Direct		24.6	24.4	24	23.7	22.8	21.7	19.1	16	11.7	5	
ND-G-2535	3Ø	3.7	5.0	Direct		31	30.6	30	29.5	29	28	25.9	23.5	19.9	12	

Note : • Available on request : Other Voltages, 60Hz.

• Subscript "F" pumps will be provided with a float switch.

LARGE VOLUME WATER PUMPS

GENERAL DATA

3 HP TO 15 HP

Performance Range

- ▶ Flow rate up to 9000 l/min. (540 m³/h)
- ▶ Dynamic head up to 6 m.

Applications

- ▶ Aquaculture water pumping and drainage for large volume water applications.
- ▶ Water supply for landscape and water features.
- ▶ Water extracting from rivers, lakes and reservoirs.
- ▶ Flood control.

Features

- ▶ Large flow capacities achieved with almost no vibration or noise by use of Propeller or Mix Flow design, giving easy operation and energy savings.
- ▶ Robust construction and compact design with a dry motor, double mechanical seal and impeller flow guide vane for high efficiency.
- ▶ Simple operation and maintenance.

Direction of Rotation

- ▶ Clockwise as seen from the motor rear end.

Specification

Diameter(mm)		200 - 250 - 300	
Pumping liquid	Ambient temp	Max. +50°C	
	Liquid temp	0°C to +50°C	
	Liquid nature	Suitable for aquaculture water pumping, flood control and water extraction from rivers, lakes and reservoir.	
Pump	Structure	Impeller	Propeller / Mixed Flow
		M.seal	Double Mechanical seal
		Bearing	Ball type bearing
	Material	Impeller	Bronze
		Volute	Grey Iron
		Upper cover	Bronze
M.seal	Carbon v/s Ceramic		
Motor	Type		Dry motor
	Insulation		F Class
	Frequency		50 Hz
	Material	Stator body	S.S AISI 304
		Shaft	S.S AISI 304
		Cable	Thermoplastic Rubber/PVC
Protection		IP 68	
Duty		S1 - When pump is completely or partially submerged.	
Voltage		3 Ph. 400 V +/-15%	

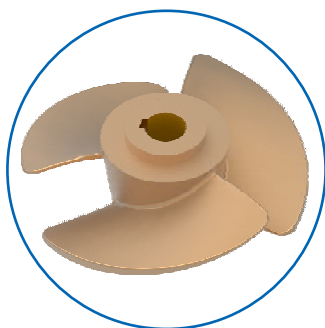
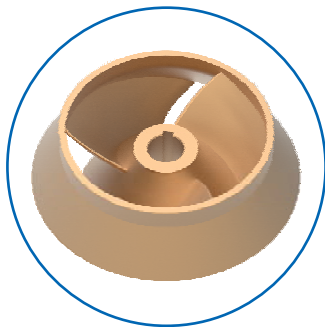

LARGE VOLUME WATER PUMPS

GENERAL DATA

3 HP TO 15 HP

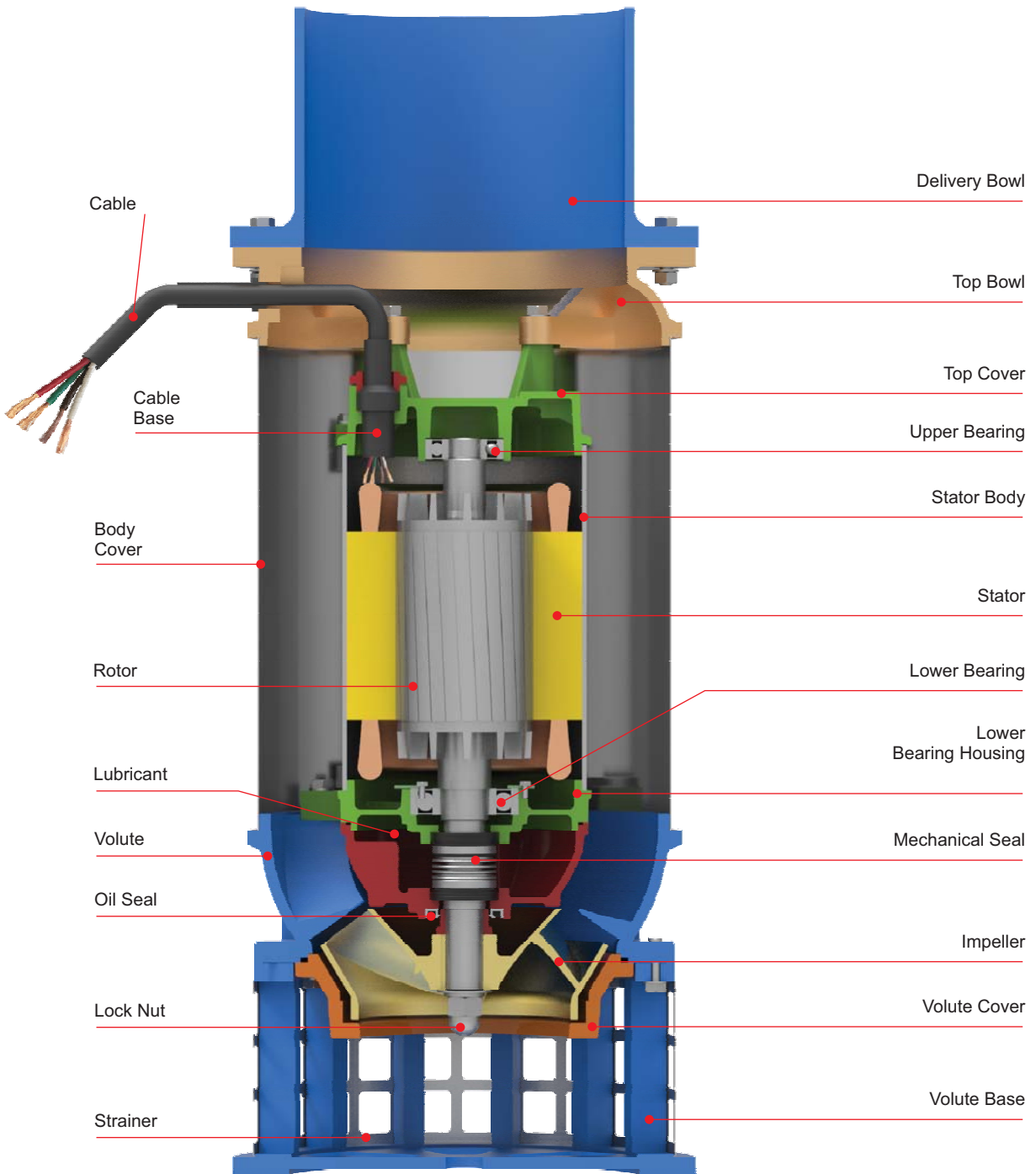

LARGE VOLUME WATER PUMPS

GENERAL DATA

3 HP TO 15 HP

General Pump Features

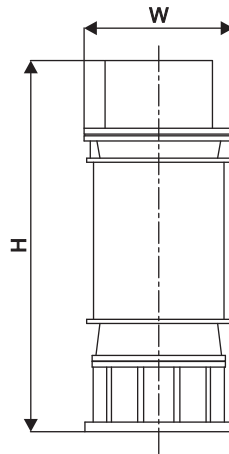

DIMENSIONS

Model	Disc. mm (Inch)	Dimensions (mm)			Solid Passage (mm)	Net Weight (kg.)	Gross Weight (kg.)	Volume (m ³)	Cable data cable x core x size (mm ²) x length (m) x Material
		Length	Width	Height					
ND-L-6335	150 (6")	-	285	638	20	52.0	91.0	0.159	1 x 4 x 1.0 x 8 x PVC
ND-L-8735	200 (8")	-	340	923	22	122.0	176.0	0.272	1 x 4 x 6.0 x 8 x PVC
ND-L-101035	250 (10")	-	380	1015	22	164.0	228.0	0.344	1 x 4 x 6.0 x 8 x PVC
ND-L-121535	300 (12")	-	430	1077	23	209.0	282.0	0.432	1 x 4 x 8.0 x 8 x Thermoplastic rubber

PERFORMANCE CHART AT n = 1450 RPM FOR HEAVY DUTY SEWAGE PUMPS

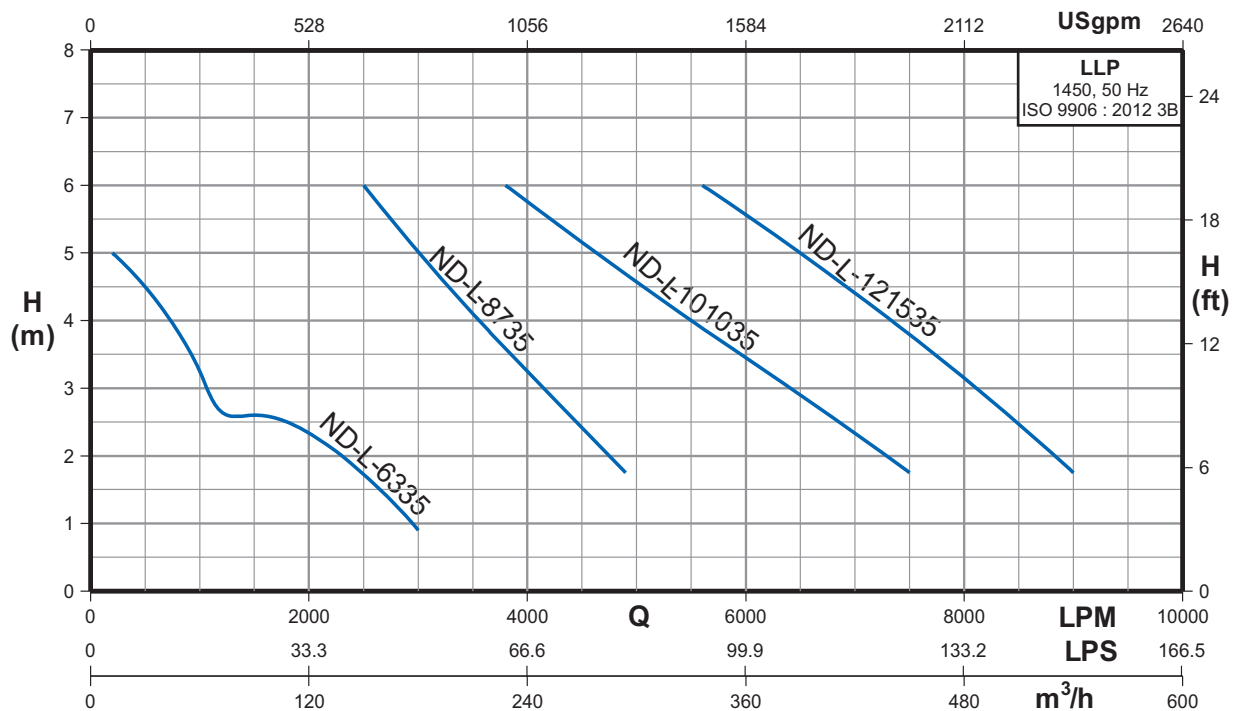

PERFORMANCE DATA AT n = 1450 RPM

MODEL	POWER		START METHOD	Flow Rate (Q)															
	kW	HP		m ³ /h	30	60	90	120	150	180	210	240	270	300	360	420	510		
Three Phase			l/min	500	1000	1500	2000	2500	3000	3500	4000	4500	5000	6000	7000	8500			
ND-L-6335	2.2	3.0	Direct	H (m)	4.5	3.2	2.6	2.3	2	-	-	-	-	-	-	-			
ND-L-8735	5.5	7.5	Direct		-	-	-	-	6	5	4.1	3.3	2.4	-	-	-			
ND-L-101035	7.5	10.0	Direct		-	-	-	-	-	-	-	5.8	5.2	4.6	3.4	2.5			
ND-L-121535	11.0	15.0	Direct		-	-	-	-	-	-	-	-	-	-	5.6	4.4	2.5		

HEAVY-DUTY CONSTRUCTION DRAINAGE PUMPS

GENERAL DATA

1.5 HP TO 10 HP

Performance Range

- ▶ Flow rate up to 2500 l/min. (150 m³/h)
- ▶ Dynamic head up to 38 m.

Applications

- ▶ Civil engineering dewatering of tunneling and ground works, also for storm water sewers.
- ▶ Dewatering of fluids containing solid sediments.

Features

- ▶ Specifically designed for civil engineering applications, where a heavy duty, light weight, top discharge design, is required which is easy to handle. The double outer casing, water cooled motor makes it particularly suitable for low water level applications.
- ▶ A fully waterproof IP 68 stainless steel structure, combined with a high grade silicon carbide double mechanical seals.
- ▶ The ND-M range of pumps are compact, strong and easy to operate in any situation.
- ▶ Special designed high efficient and wear resistant HCR (High Chrome) impeller.
- ▶ Multi impeller design suitable from high head with small capacity to low head with large capacity of application requirement.
- ▶ Optional discharge connection (Hose, flange and thread connection)

Direction of Rotation

- ▶ Clockwise as seen from the motor rear end.

Special Features on Request

- ▶ Other voltages.
- ▶ Available in 60Hz.

Thermal overload protector

- ▶ Equipped with Automatic reset motor protector, prevents motor from burning due to high temperature/phase failure/voltage drop and locked impeller.



HCR Impeller

- ▶ The ND-M impeller is manufactured with a high chrome alloy (HCR) steel with a hardness of 55 - 60 Rc., which makes it resistant to prolonged use in abrasive applications.



Specification

HP		1.1 to 3.7 kW	5.5 to 7.5 kW		
Diameter (mm)		50 - 80	80	100 - 150	
Pumping liquid	Ambient temp	Max. +50°C			
	Liquid temp	0°C to +50°C			
	Liquid nature	Suitable for dewatering at civil engineering sites and pumping of storm water.			
Pump	Structure	Impeller	Open	Open	Enclosed
		Mech. seal	Double Mechanical seal		
		Bearing	Ball type bearing		
	Material	Body cover	S.S. AISI 304L		
		Upper cover	Grey Iron		
		Volute	Grey Iron		
		Impeller	HCR		
M. seal	Wear Ring	-	-	HCR	
	Motor Side	Carbon v/s Ceramic			
Pump Side	Silicon Carbide v/s Silicon Carbide				
Motor	Type	Dry motor			
	Insulation	F Class			
	Frequency	50 Hz			
	Thermal Protector	Automatic reset motor protector			
	Material	Stator body	S.S. AISI 304L	Grey Iron	
		Shaft	S.S. AISI 410		
Cable		Thermoplastic Rubber/PVC			
Protection	IP 68				
Duty	S1 - When pump is completely or partially submerged.				
Voltage	1 Ph. 230 v +5/-15%, 3 Ph. 400 v +5/-15%		3 Ph. 400 v +5/-15%		

HEAVY-DUTY CONSTRUCTION DRAINAGE PUMPS

MATERIALS OF CONSTRUCTION

1.5 HP TO 10 HP

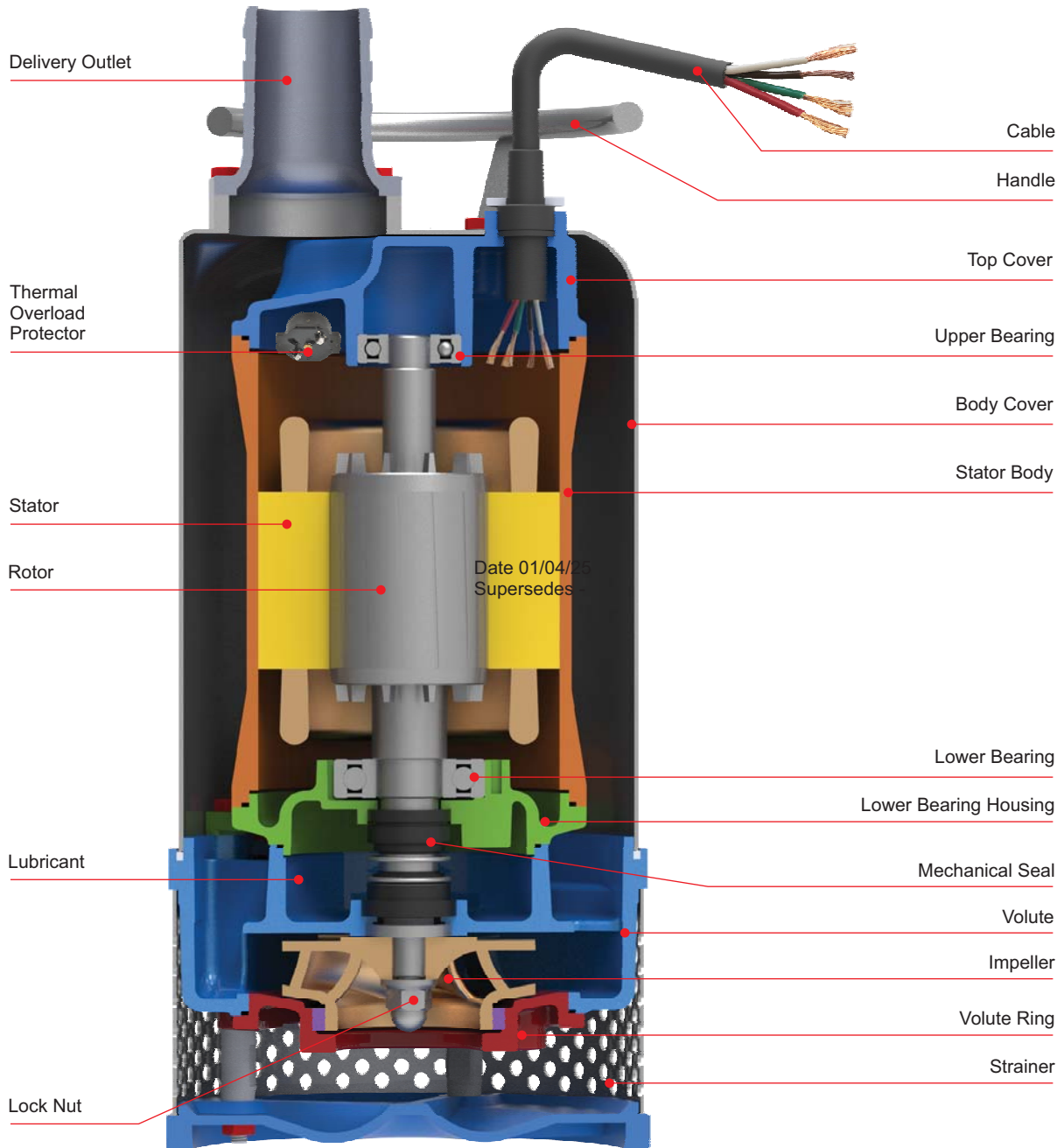

HEAVY-DUTY CONSTRUCTION DRAINAGE PUMPS

GENERAL DATA

1.5 HP TO 10 HP

Specification

HP		11 to 15 kW	
Diameter (mm)		100 - 150	
Pumping liquid	Ambient temp	Max. +50°C	
	Liquid temp	0°C to +50°C	
	Liquid nature	Suitable for dewatering at civil engineering sites and pumping of storm water.	
Pump	Structure	Impeller	Enclosed
		Mech. seal	Double Mechanical seal
		Water detector	Installed in the seal chamber to detect water leakage from water infiltrating
		Bearing	Ball type bearing
	Material	Body cover	S.S. AISI 304L
		Upper cover	Grey Iron
		Volute	Grey Iron
		Impeller	HCR
	M. seal	Wear Ring	HCR
		Motor Side	Carbon v/s Ceramic
	Pump Side	Silicon Carbide v/s Silicon Carbide	
Motor	Type	Dry motor	
	Insulation	F Class	
	Frequency	50 Hz	
	Thermal Protector	Miniature Thermal Protector	
	Material	Stator body	Grey Iron
		Shaft	S.S. AISI 410
		Cable	Thermoplastic Rubber/PVC
Protection	IP 68		
Duty	S1 - When pump is completely or partially submerged.		
Voltage	3 Ph. 400 v +/-15%		

Performance Range

- ▶ Flow rate up to 2600 l/min. (156 m³/h)
- ▶ Dynamic head up to 57 m.

Applications

- ▶ Civil engineering dewatering of tunneling and ground works, also for storm water sewers.
- ▶ Dewatering of fluids containing solid sediments.

Features

- ▶ Specifically designed for civil engineering applications, where a heavy duty, light weight, top discharge design, is required which is easy to handle. The double outer casing, water cooled motor makes it particularly suitable for low water level applications.
- ▶ A water detector is provided in the seal chamber. In case of seal failure if water enters the seal chamber, a signal can be sent to the control panel so that the pump operator is made aware of a potential seal leakage problem.
- ▶ A fully waterproof IP 68 stainless steel structure, combined with a high grade silicon carbide double mechanical seals.
- ▶ The ND-M range of pumps are compact, strong and easy to operate in any situation.
- ▶ Special designed high efficient and wear resistant HCR (High Chrome) impeller.
- ▶ Multi impeller design suitable from high head with small capacity to low head with large capacity of application requirement.
- ▶ Optional discharge connection (Hose, flange and thread connection)

Direction of Rotation

- ▶ Clockwise as seen from the motor rear end.

Special Features on Request

- ▶ Other voltages.
- ▶ Available in 60Hz.

Miniature Thermal Protector

- ▶ Miniature Thermal Protector (MTP) is embedded in the windings of the motor. The MTP will transmit a signal to a control panel when windings temperature reaches a set point.

HCR Impeller

- ▶ The ND-M impeller is manufactured with a high chrome alloy (HCR) steel with a hardness of 55 - 60 Rc., which makes it resistant to prolonged use in abrasive applications.



HEAVY-DUTY CONSTRUCTION DRAINAGE PUMPS

MATERIALS OF CONSTRUCTION

1.5 HP TO 10 HP

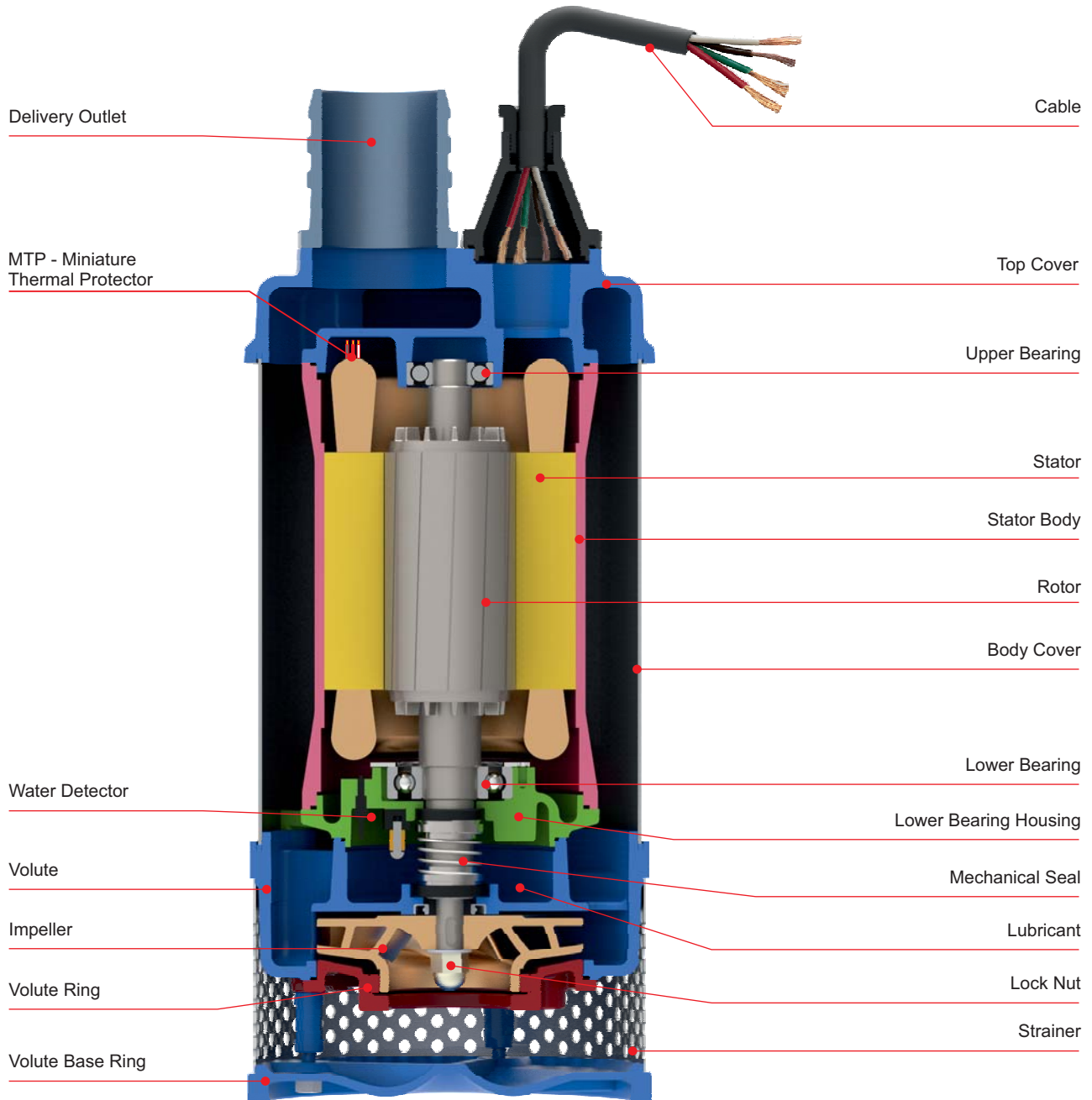

HEAVY-DUTY CONSTRUCTION DRAINAGE PUMPS

GENERAL DATA

1.5 HP TO 10 HP

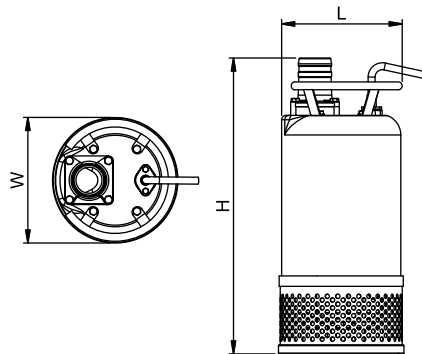

DIMENSIONS

Model		Disc. mm (Inch)	Dimensions (mm)			Solid Passage mm	Net Weight (kg.)	Gross Weight (kg.)	Volume (m ³)	Cable data cable x core x size (mm ²) x length (m) x Material
Single Phase	Three Phase		Length	Width	Height					
ND-M 21A15/21A15F	-	50 (2")	210	210	510	8	29.0	49.0	0.077	1 x 3 x 1.0 x 5 x PVC
-	ND-M 21A35/21A35F		210	210	435	8	25.0	45.0	0.068	1 x 4 x 1.0 x 5 x PVC
ND-M 3215/3215F	-	80 (3")	250	240	630	11	43.0	68.0	0.111	1 x 3 x 2.0 x 8 x PVC
-	ND-M 3235/3235F		250	240	535	11	39.0	64.0	0.097	1 x 4 x 1.8 x 8 x PVC
ND-M 3315/3315F	-	80 (3")	250	240	645	11	47.0	72.0	0.113	1 x 3 x 3.5 x 8 x PVC
-	ND-M 3335/3335F		250	240	560	11	42.0	67.0	0.101	1 x 4 x 1.8 x 8 x PVC
-	ND-M 3535	80 (3")	250	240	600	11	46.0	71.0	0.107	1 x 4 x 1.8 x 8 x PVC
-	ND-M 3735	80 (3")	290	290	690	10	74.0	102.0	0.150	1 x 4 x 3.5 x 8 x PVC
-	ND-M 4735	100 (4")	290	290	690	10	76.0	104.0	0.150	1 x 4 x 3.5 x 8 x PVC
-	ND-M 6735	150 (6")	290	290	745	10	78.0	106.0	0.160	1 x 4 x 3.5 x 8 x PVC
-	ND-M 41035	100 (4")	290	290	690	10	76.0	104.0	0.150	1 x 4 x 3.5 x 8 x PVC
-	ND-M 61035	150 (6")	290	290	745	10	80.0	108.0	0.160	1 x 4 x 3.5 x 8 x PVC
-	ND-M 41535	100 (4")	290	290	725	10	82.0	112.0	0.170	1 x 7 x 6.0 x 8 x Thermoplastic rubber 1 x 3 x 0.75 x 8 x Thermoplastic rubber
-	ND-M 61535	150 (6")	290	290	785	10	86.0	116.0	0.180	1 x 7 x 6.0 x 8 x Thermoplastic rubber 1 x 3 x 0.75 x 8 x Thermoplastic rubber
-	ND-M 42035	100 (4")	332	332	770	10	142.0	185.0	0.200	1 x 7 x 6.0 x 8 x Thermoplastic rubber 1 x 3 x 0.75 x 8 x Thermoplastic rubber

PERFORMANCE CHART AT n = 2900 RPM FOR CONSTRUCTION DRAINAGE PUMP

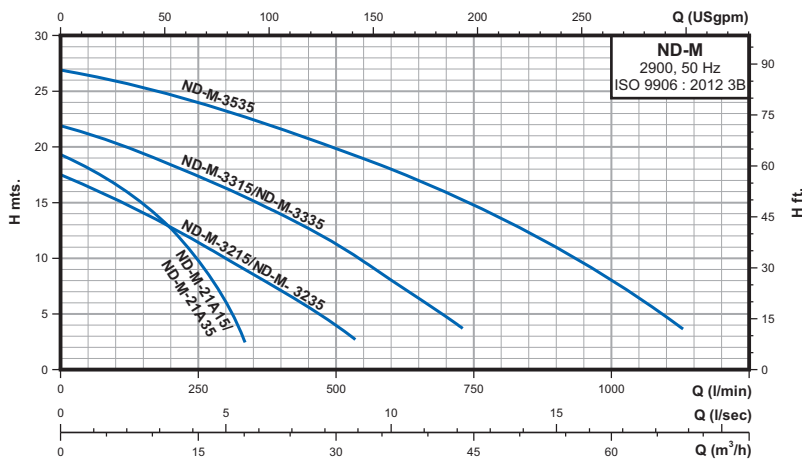

PERFORMANCE DATA AT n = 2900 RPM

Model		Power		Start Method	m ³ /h l/min	6	12	18	24	30	36	42	48	60	66	
Single Phase	Three Phase	kW	HP			100	200	300	400	500	600	700	800	1000	1100	
ND-M 21A15/21A15F	-	1.1	1.5	Capacitor	H m	16.5	12.5	6	-	-	-	-	-	-	-	
-	ND-M 21A35/21A35F			Direct												
ND-M 3215/3215F	-	1.5	2.0	Capacitor		15.3	12.8	10	7	4	-	-	-	-	-	-
-	ND-M 3235/3235F			Direct												
ND-M 3315/3315F	-	2.2	3.0	Capacitor		20.3	18.4	16.4	14	12.5	8	5.5	-	-	-	-
-	ND-M 3335/3335F			Direct												
-	ND-M 3535	3.7	5.0	Direct		26	24.5	23.3	21.6	19.9	18	16	13.5	8	4.7	

Note : Subscript "F" pumps will be provided with a float switch.

HEAVY-DUTY CONSTRUCTION DRAINAGE PUMPS

GENERAL DATA 1.5 HP TO 10 HP

PERFORMANCE CHART AT n = 2900 RPM FOR CONSTRUCTION DRAINAGE PUMP

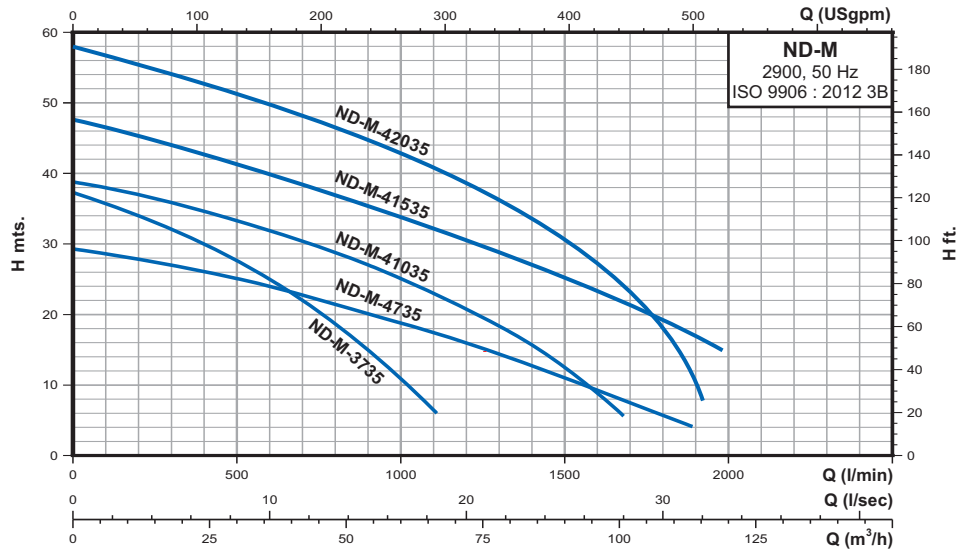

PERFORMANCE DATA AT n = 2900 RPM

Model	Power		Start Method	m³/h l/min	12	18	24	30	36	48	54	60	66	72	84	96	108
	kW	HP			200	300	400	500	600	800	900	1000	1100	1200	1400	1600	1800
ND-M 3735	5.5	7.5	Direct	H m	34.0	32.0	30.0	27.5	25.0	18.6	15.0	11.0	6.2	-	-	-	-
ND-M 4735			Direct		27.9	27.0	26.0	25.0	24.0	21.5	20.0	18.8	17.5	16.0	12.7	9.20	5.7
ND-M 41035	7.5	10.0	Direct		37.0	35.9	34.6	33.4	32.0	28.8	27.0	25.0	23.0	20.8	15.6	9	-
ND-M 41535	11.0	15.0	Y - Δ		45.3	44.0	42.7	41.3	39.9	37.0	35.4	33.8	32.2	30.5	27.0	23.3	19.3
ND-M 42035	15.0	20.0	Y - Δ		55.5	54.0	52.8	51.2	50.0	46.5	44.8	42.8	40.8	38.6	33.7	27.0	8.0

PERFORMANCE CHART AT n = 2900 RPM FOR CONSTRUCTION DRAINAGE PUMP

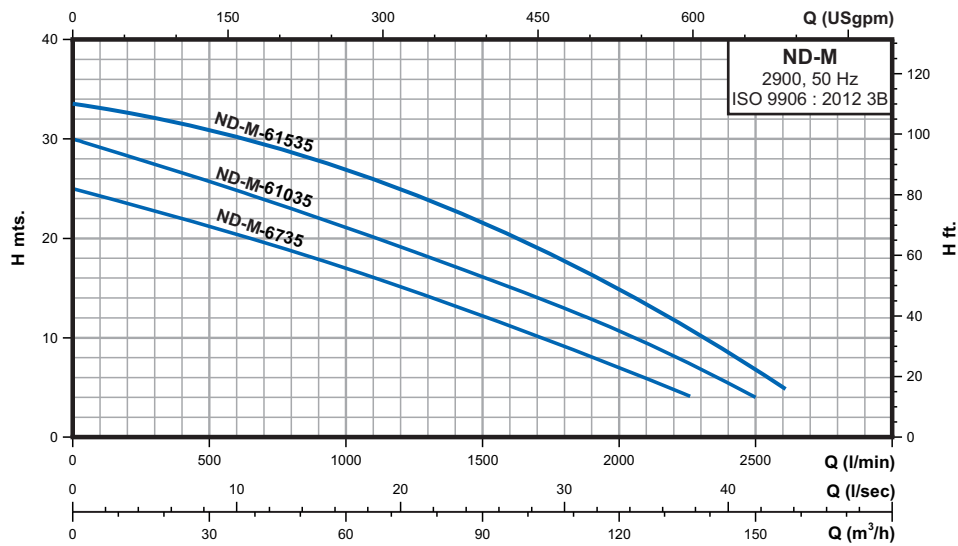

PERFORMANCE DATA AT n = 2900 RPM

Model	Power		Start Method	m³/h l/min	18	36	54	72	90	108	126	144
	kW	HP			300	600	900	1200	1500	1800	2100	2400
ND-M 6735	5.5	7.5	Direct	H m	22.8	20.5	18.0	15.0	12.1	9.0	6.0	-
ND-M 61035	7.5	10.0	Direct		27.5	24.9	22.0	19.0	16.0	13.0	9.4	5.4
ND-M 61535	11.0	15.0	Y Δ		32.1	30.2	27.8	26.0	21.5	17.7	14.9	8.6



Northam Inc.

995/C Griffin Pond Road, Clarks Summit, PA 18411, USA
Phone : +1-570-659-7200, Email : sales@northam-inc.com

Product Improvement and changes are a continuous process at 'Northam'. The data given in this publication is therefore subject to revision.