

Installation and Operating Instructions

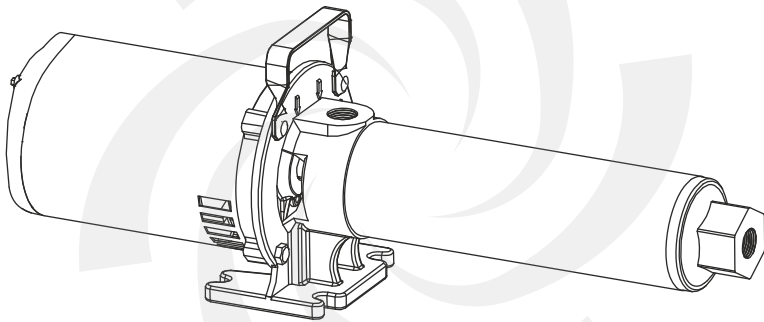

Horizontal Multistage Booster Pumps

TABLE OF CONTENTS

PURCHASER'S INFORMATION

PURCHASER'S INFORMATION	2
GENERAL DATA	3
GENERAL SAFETY INFORMATION	4
INSTALLATION	5
ELECTRICAL CONNECTIONS	7
START-UP & MAINTENANCE	8
TROUBLESHOOTING	9

Pump Model #:	_____
Pump Serial #:	_____
Dealer Name:	_____
Dealer Telephone:	_____
Purchase Date:	_____
Installation Date:	_____
Volts:	_____
Amps:	_____

GENERAL DATA

DESCRIPTION

NORTHAM Horizontal Multistage Booster Pumps shall provide you with years of reliable, efficient and safe pumping solution for your water boosting needs provided the installation is carried out as described in this manual.

Before installing, operating, and maintaining the horizontal multistage booster pump, it's essential to read these instructions. Additionally ensure that the horizontal multistage booster pump is not utilized until all safety conditions outlined in the instruction manual are satisfied.

The purpose of the instructions, warnings, cautions and notes included in this manual is to help you become familiar with the product and its allowed uses.

The instructions may not take into account local regulations; ensure such regulations are properly complied by all, including those installing the product. Ensure that installation and operation adhere to local regulations and accepted standards of good practice.

These instructions apply specifically to NORTHAM horizontal multistage booster pumps.

Before proceeding with installation, carefully review these instructions for safe and proper installation.

SPECIFICATIONS

- The NORTHAM Horizontal Multistage Booster Pump can be used for residential, commercial and industrial application. It can also be used in Reverse Osmosis or filtration of water.
- Maximum liquid temperature: 160°F (71°C).
- Maximum suction pressure: 75 psi.
- Motors are NEMA standard.
- Motors are of Open Drip proof (ODP) fan ventilated construction.
- Motors are suitable for 115/230V, 60 Hz, single phase power supply.
- Available ratings: 0.75 to 2 hp
- Suction & discharge port size: 1" NPT.

SYMBOLS USED IN THIS DOCUMENT



Warning

Neglecting these safety instructions could result in explosion, fire or electric shock, posing a significant risk of severe personal injury, or even death, as well as property damage.

Caution

Failure to adhere to these safety instructions may lead to equipment malfunction or damage.

Note

These notes or instructions aim to streamline the task and ensure safe operation.

GENERAL SAFETY INFORMATION



During installation, operation as well as servicing of the booster pumps follow safety instructions as listed below. Failure to follow these instructions may result in electrical shock, fire hazard, personal injury or death, equipment damage, inadequate product performance and may also void manufacturer's warranty.

SAFETY INSTRUCTIONS

- The pump should be installed, connected to power source and serviced by qualified electrician only.
- During installation, operation as well as servicing of the pump, do not touch any electrical components when power supply is switched on.
- Ensure all power sources are disconnected and locked in OFF position when installing or repairing the pump.
- Follow all appropriate electrical codes.
- Always follow the National Electrical Code (NEC), or the Canadian Electrical Code. Check local codes and regulations before installation. The installation must comply with these requirements.
- Failure to follow electrical codes & OSHA safety standards could lead to personal injury or death and may also lead to damage of the equipment.
- Do not use in explosive atmospheres or hazardous environment.
- Do not use to pump flammable, combustible, or explosive liquids such as gasoline, oil, kerosene, etc.
- This pump should be used to pump clear water only.
- Please wear protective clothes and safety glasses for personal protection when installing or repairing the pump.
- Operators should be properly instructed on operating procedures & safety guidelines.
- Pump must be lifted manually or by means of a hoist.
- Pump with Motor should always be electrically grounded. Motor cable shall only be connected to power source after grounding is done.
- Lock the mains switch in "OFF" position when maintenance is progress.
- Do not put your hands or any tool into the pump suction or discharge port after the pump has been connected to the power supply, unless the pump has been switched off by removing the fuses or switching off and locking the mains switch in OFF position. It must be ensured that the power supply cannot be accidentally switched on.
- Do not handle a pump or pump motor with wet hands, and never stand on a wet or moist surface or in water.
- When the pump is in operation, do not touch the motor, pipes or water until the unit is unplugged or electrically disconnected.
- Avoid operating the pump at shutoff pressure since the high temperature can cause damage the pump.
- Do not let the pump run dry. If so, the pump seal and other pump parts will sustain damage.
- Keep work area clean, well-lit, and uncluttered.
- Always use only original genuine factory spare parts.
- Please keep out of the reach of children.

INSTALLATION



Before commencing the installation, ensure to turn off the power supply and securely lock the main switch in the OFF position.

Caution The pump is not submersible so keep the motor dry at all times, Do not wash or soak the motor.

PRE-INSTALLATION CHECKLIST

Before initiating the installation procedures, please conduct the following checks:

- Inspect all components for potential damage during transit and notify the shipping carrier or your dealer/distributor if any damage is found.
- Ensure that the power supply matches with the motor.
- When handling the pump hold firmly on the handle with one hand and pump with the other hand. Always handle with care to avoid damaging the pump, motor and shaft seal.
- Install the pump in clean, dry location with sufficient accessibility for inspection, maintenance as well as ventilation, while also shielding the unit where pump and piping are protected from the weather and extreme of heats, humidity, rain, flooding or freezing temperatures.
- The pump should preferably mounted horizontally on a stable, flat surface.
- Piping should match the size of suction and discharge connections.
- Install the pump as close as possible to the supply of pumped liquid and piping should be kept as short as possible to reduce friction losses, avoiding unnecessary fittings.
- All piping must be supported independently ensuring that no loads are placed on the pump itself.
- Inspect all piping connections to ensure they are tight and completely sealed with PTFE thread sealing tape.

All of these checks are essential for correctly installing the booster pump and it's imperative to adhere to all safety regulations during the installation process.



Install a pressure relief valve on all installations. It is possible for pump pressure to exceed the maximum operating pressure of the system. Pressure relief valve provide a method to safely relieve excess system pressure. Excessive pressure can lead to personal injury and property damage.

Caution To ensure consistent functioning, the pump's internal running surfaces and mechanical shaft seal must be lubricated with water. Do not let the pump run dry. If so, the pump seal and other pump parts will sustain damage.

By using a foot valve and priming tee, the pump can transfer water from a reservoir, tank, or pond with a maximum suction lift of 5 feet. The suction height varies depending on altitude and temperature of water.



Operating the pump with discharge valve closed may result in severe internal damage due to increase in temperature of water.

Pump should not operate with water temperature above 140°F to avoid internal damage to the pump. Pump must be filled with water before operation. Do not pump dirty water or abrasive liquids, as this will cause wear and leakage of the carbon seal surface and the elastomer in the seal. Avoid air pockets in the suction pipe, otherwise air will collect in the highest parts and make suction difficult (see figure 1).

PIPEWORK CONNECTION



Operating the pump with discharge valve closed may result in severe internal damage due to increase in temperature of water.

Caution To ensure consistent functioning, the pump's internal running surfaces and mechanical shaft seal must be lubricated with water. Do not let the pump run dry. If so, the pump seal and other pump parts will sustain damage.

Note Avoid coercing the piping into position at the pump's suction and discharge connection.

INSTALLATION

TYPICAL INSTALLATION

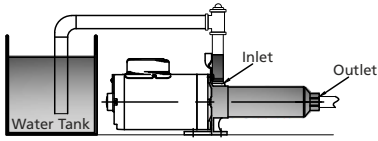

AIR COULD GET TRAPPED IN SUCTION PIPE
INSTALLATION NOT RECOMMENDED

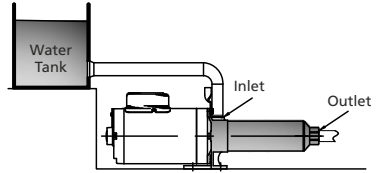

POSITIVE SUCTION - EASY PRIMING
RECOMMENDED INSTALLATION

Fig. 1 TYPICAL PUMP INSTALLATION

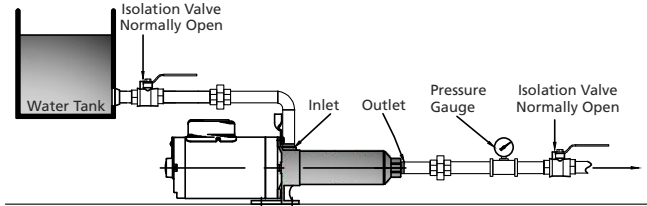

Fig. 2 INSTALLATION - FLOODED SUCTION CONDITION

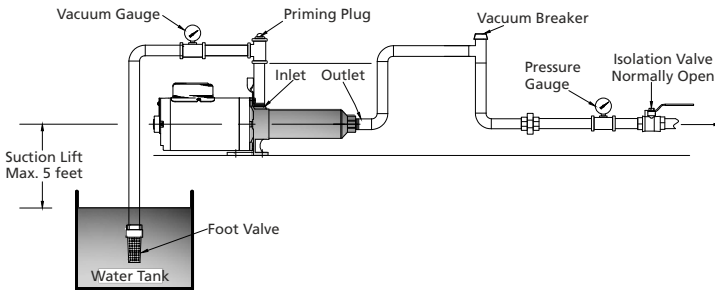
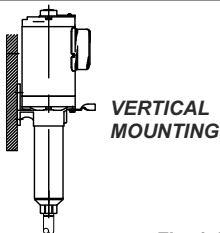
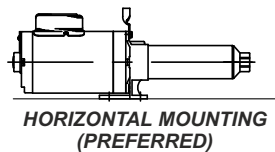

Fig. 3 INSTALLATION - SUCTION LIFT CONDITION



**VERTICAL
MOUNTING**



**HORIZONTAL MOUNTING
(PREFERRED)**

Fig. 4 TYPICAL MOUNTING POSITION

ELECTRICAL CONNECTIONS

GENERAL

The electrical connections should be carried out by an authorised electrician in accordance with local regulations.



Always follow the National Electrical Code (NEC), or the Canadian Electrical Code. Also check local codes and regulations. The pump must always be connected to a suitable electrical ground.



Ensure all power sources are disconnected when installing or servicing the pump.



Failure to establish a permanent ground connection for the pump, motor, and controls before connecting to electrical power can result in the risk of electric shock, burns or even fatal injury.



The operating voltage and frequency are stated on the motor nameplate. Make sure that the motor is suitable for the electricity supply at the installation site.



Install an electrical power cutoff switch for all legs in close proximity to the pump.

- Carefully adhere to the wiring diagram provided by NORTHAM on the motor nameplate or refer to fig. 5 and fig.6 below for correct wiring.
- Exclusively utilize copper wire for connecting to the motor and ground. Ensure that the ground wire is of equal or larger gauge compared to the wire used for the motor. Employ color-coding for wires to facilitate maintenance tasks.

WIRING DIAGRAMS

- All single-phase motors are dual voltage suitable for 115/230V volts operations.
- The motors are shipped from factory, wired for 230V operation.
- Based on power supply available at the installation site wire connections may have to be change for 115V operation.
- Kindly refer wiring diagram as shown below for connection and safe operation of the pump.
- Connect the ground wire identified by its Green color, to the designated Green ground screw



Connecting pump motor to incorrect supply voltage could result in fire, electric shock, posing a significant risk of severe personal injury, or even death, as well as property damage.

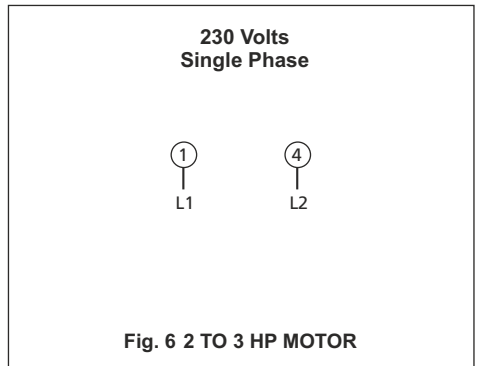
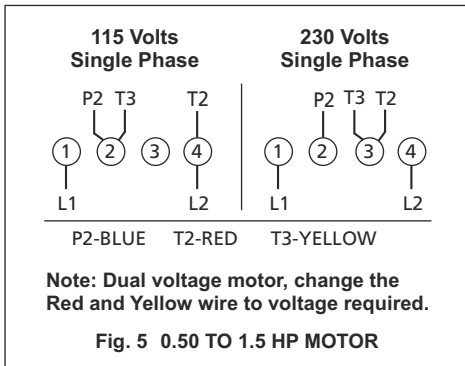

DIRECTION OF ROTATION

For single-phase pumps, the direction of rotation is predetermined and is not required to be checked.

Caution

In the case of three-phase pumps kindly check direction of rotation and if it is not correct interchange any two power supply leads.

START-UP & MAINTENANCE

OPERATION



Open drip proof motors that have been splashed or submerged in liquids may short out and result in fire, electric shock, burns, or even death.

Note Pump must be fully primed before operation, do not run pump dry.



Operating the pump with the discharge valve closed may produce hot water or steam, leading to potential injury or property damage. Avoid running against the closed nozzle for extended periods of time as this can damage the pipes and pump. Do not run pump dry without priming, as it will cause damage to the mechanical seal.

- 1) For Suction Lift installations (Fig 3), the pump shall have to be primed before operation
 - First remove the priming plug.
 - Pour water through the priming port (priming opening on the top of tee as shown in the figure 3).
 - Fill the pump and piping with clear water.
 - Rotate the motor shaft to remove any air from the housing.
 - Refill the pump with motor at the priming port and replace the priming plug using PTFE thread sealing tape.
- 2) Next, start the pump and slightly open the discharge valve, allowing the system pressure to settle.
- 3) If there is any surging in system pressure or if pressure drops for an extended period, it indicates that the system might not be fully primed.
- 4) Once the pump is running perfectly, fully open the discharge valve and system outlet.

Caution If the pump does not deliver water within a few seconds, stop the motor and start the pump again. Multiple start attempts may be required to remove all air from the pump and suction line.

MAINTENANCE



Before conducting maintenance of pump, make sure that the electricity supply has been switched off and locked in OFF position and that it cannot be accidentally switched on. Failure to disconnecting electrical power could lead to electrical shock, burns, or even fatal injuries.

- Lubrication is not required for the pump or motor.
- Have maintenance performed immediately if abnormal noises, leaks, or vibrations occur.
- Empty pump if it is going to be exposed to freezing temperatures.

DRAINING THE PUMP / SEASONAL MAINTENANCE

When taking the pump out of service, or if the pump is going to be exposed to freezing conditions

- 1) Ensure to remove all drain plugs, drain all pipings and tank completely.
- 2) When putting the pump back into service, reinstall all drain plug using PTFE thread sealing tape.
- 3) Reconnect the suction line if it was disconnected.
- 4) Prime the pump again and operate it according to the instructions and warnings provided in the manual.

TROUBLESHOOTING



Before removal/dismantling of the pump, make sure that the electricity supply has been switched off and locked in OFF position and cannot be accidentally switched on. All rotating parts must have stopped moving.

FAULT	CAUSE	REMEDY
THE PUMP/MOTOR DOES NOT RUN.	<ol style="list-style-type: none"> 1) The fuses are blown. 2) The circuit breaker has tripped out. 3) Inadequate power supply. 4) No electricity supply. 5) Motor thermal overload protector has tripped out. 6) The pump is defective/worn. 7) Motor is incorrectly wired. 	<ol style="list-style-type: none"> 1) Replace the blown fuses. 2) Cut in the circuit breaker. 3) Check power supply 4) Contact the electricity supply company. 5) For single-phase motor, thermal overload protector will automatically reset once motor gets cool, repair it if required. 6) Repair/replace the pump. 7) Correct the motor wiring.
THE PUMP RUNS BUT DELIVERS LITTLE OR NO WATER.	<ol style="list-style-type: none"> 1) Incorrect direction of rotation for 3 phase pumps. 2) The pump is defective/worn. 3) The suction piping is defective. 4) The pump is located too far from the liquid source. 5) The gate valve is closed. 6) The strainer is blocked or defective. 7) The foot valve is malfunctioning. 8) The discharge height or length is excessive. 9) Motor is wired for incorrect voltage, 	<ol style="list-style-type: none"> 1) Interchange any two power supply leads. 2) Repair/replace the pump. 3) Replace the piping. 4) Relocate the pump. 5) Open the valve. 6) Clean/repair/replace the strainer. 7) Clean or replace the valve. 8) Lower the discharge point and shorten the piping. 9) Check and correct the wiring.
EXCESSIVE NOISE WHILE PUMP IN OPERATION.	<ol style="list-style-type: none"> 1) The pump is not anchored to a stable base. 2) The piping lacks support to ease pressure on the pump unit. 3) The suction line is narrowed or restricted. 4) Noisy motor. 5) Motor is wired for incorrect voltage, 6) Inadequate supply voltage. 	<ol style="list-style-type: none"> 1) Securely fasten the pump. 2) Make any required modifications. 3) Clean and rectify the suction line. 4) Repair/replace the motor. 5) Check and correct the wiring. 6) Check power supply voltage and contact the electricity supply company.
PUMP LEAKS	<ol style="list-style-type: none"> 1) Mechanical shaft seal is misaligned. 2) Worn, pinched o-ring seals. 3) Worn mechanical shaft seal due to abrasive liquid or rust 4) Lack of water - Dry run has damaged the mechanical shaft seal. 5) Inlet pressure too high 	<ol style="list-style-type: none"> 1) Check for a bent motor shaft. 2) Replace O-ring seals. 3) Install filter on inlet line. 4) Replace mechanical shaft seal and o-ring. Check inlet pressure if it is 2 PSIG or not. 5) Reduce inlet pressure.

NOTES

NOTES



Northam Inc.

995/C Griffin Pond Road, Clarks Summit, PA 18411, USA

www.northam-inc.com
